

Landspítali University Hospital of Iceland

2. Draft
Space Gap Analysis and Alternative Solutions
Functional Development Plan
04.04.2001



Table of Content

	Page
1 INTRODUCTION	1
2 PATIENT PROFILE AND VOLUME	3
2.1 <u>INPATIENTS 2020</u>	5
2.2 <u>LOS 2020</u>	5
2.3 <u>DAY PATIENTS 2020</u>	6
2.4 <u>OUTPATIENTS 2005</u>	6
2.5 <u>SUMMARY OF PATIENT TRANSFER</u>	7
3 ESTIMATION OF THE STAFF VOLUME 2020	9
3.1 <u>THE STAFFING MODEL</u>	9
3.1.1 <u>Input to the model</u>	9
3.1.2 <u>Calculations in the model</u>	10
3.2 <u>CLINICAL FUNCTIONS</u>	10
3.2.1 <u>Model A – unchanged productivity (the 1999-level is kept unchanged)</u>	11
3.2.2 <u>Model B – improved productivity inspired by benchmarking</u>	11
3.2.3 <u>Comparison of model A and B</u>	14
3.3 <u>CLINICAL SERVICE FUNCTIONS AND OTHER SERVICE FUNCTIONS</u>	15
3.4 <u>STAFFING 2020</u>	16
4 CLINICAL FUNCTIONS IN 2020	17
4.1 <u>PATIENT WARDS</u>	17
4.2 <u>DAY PATIENT SERVICES</u>	17
4.3 <u>OUT-PATIENT SERVICES AND SPECIALIZED DIAGNOSTIC SERVICES</u>	18
4.4 <u>OFFICES AND MEETING ROOMS</u>	19
5 CLINICAL SERVICE FUNCTIONS IN 2020	20
5.1 <u>EMERGENCY DEPARTMENT</u>	20
5.2 <u>OPERATIONAL THEATRES</u>	20
5.3 <u>RECOVERY, INTENSIVE CARE AND ANESTHETICS</u>	22
5.4 <u>RADIOLOGY AND DIAGNOSTIC IMAGING</u>	23
5.5 <u>LABORATORY</u>	23
5.6 <u>OCCUPATIONAL AND PHYSIOTHERAPY</u>	23
5.7 <u>ARCHIVES FOR MEDICAL RECORDS AND X-RAY FILES</u>	24
6 EDUCATION AND UNIVERSITY FUNCTIONS IN 2020	25
6.1 <u>AUDITORIUM</u>	25
6.2 <u>UNIVERSITY FUNCTIONS FOR STUDENTS</u>	25
6.3 <u>RESEARCH</u>	26
6.4 <u>MEDICAL LIBRARY</u>	27
7 SERVICE FUNCTIONS IN 2020	28
7.1 <u>KITCHEN</u>	28
7.2 <u>ADMINISTRATION</u>	28
7.3 <u>PATIENT SERVICE</u>	28

7.4	<u>STAFF SERVICE</u>	28
7.5	<u>OTHER SERVICE FUNCTIONS</u>	28
8	<u>DETERMINATION OF FUTURE SPACE</u>	29
8.1	<u>METHODOLOGY</u>	29
8.1.1	<u>Utilization rate</u>	30
8.1.2	<u>Space standards</u>	31
8.2	<u>THEORETICAL SPACE ESTIMATIONS</u>	32
9	<u>DETERMINATION OF PRESENT SPACE</u>	35
9.1	<u>PRESENTATION OF THE PRESENT SPACE - FOSSVOGUR</u>	35
9.2	<u>PRESENTATION OF THE PRESENT SPACE – HRINGBRAUT</u>	37
9.3	<u>TOTAL PRESENT SPACE</u>	40
10	<u>GAP ANALYSIS</u>	41
10.1	<u>GAP 1 - 2001</u>	41
10.2	<u>GAP 2 - 2020</u>	42
11	<u>LOGISTICAL DEMANDS FOR THE FUTURE</u>	43
11.1	<u>GENERAL PRINCIPLES</u>	43
11.2	<u>FUTURE LOCATION AND LOGISTICS</u>	47
12	<u>SUGGESTION FOR A SHORT-TERM SOLUTION</u>	49
13	<u>SUGGESTIONS FOR ALTERNATIVE LONG-TERM SOLUTIONS</u>	51
13.1	<u>ALTERNATIVE A1. FURTHER DEVELOPMENT OF THE SHORT-TERM SOLUTION</u>	51
13.2	<u>ALTERNATIVE A2. MORE BEDS IN FOSSVOGUR</u>	51
13.3	<u>ALTERNATIVE B1 AND B2. ONE SOMATIC HOSPITAL</u>	52
13.3.1	<u>B1. Fossvogur as the somatic hospital</u>	52
13.3.2	<u>B2. Hringbraut as the somatic hospital</u>	53
13.4	<u>ALTERNATIVE C. NEW HOSPITAL</u>	55
13.5	<u>SUMMARIZING</u>	55

Appendices are printed in a separate report

Appendix 1:	Patient volume 1999
Appendix 2:	Extrapolation 2020
Appendix 3:	Staff profile and volume from LSH 1999
Appendix 4:	Staffing model A and B for 2020
Appendix 5:	Staff benchmarking
Appendix 6:	Present space Fossvogur
Appendix 7:	Present space Hringbraut
Appendix 8:	Future space calculations
Appendix 9:	Examples of secondary rooms

Appendix 10: Gap analysis

Appendix 11: Space balance for the solutions

1 Introduction

Landspítali and Sjúkrahús Reykjavíkur have merged to one hospital: Landspítali University Hospital (LSH).

The new hospital is located at various building complexes in the Reykjavík area, where the two main locations are Hringbraut and Fossvogur. Other important locations are Vífilstadir, Kopavogur, Kleppur, Grensás and Landakot.

In order to analyze the physical building situation for the new university hospital for Iceland, the Management has engaged Ementor Denmark A/S to assist in the process and to prepare a Functional Development Plan for LSH, concentrating on the two main complexes at Fossvogur and Hringbraut.

The purpose of a Functional Development Plan for Landspítali is to

- Create a short-term plan (year 2001/2002) based on the given conditions and set up of functions, location of specialties etc. at the hospital today.
- Create a long-term (until year 2020) integrated plan for the functional and building development of the hospital, in order to remove bottlenecks, achieve good logistics, minimize the investment costs and to support the operational procedures in the most efficient way
- Create an instrument for project and cost control in the building/implementation period

Furthermore the plan must consider the future patient profile and volume of the hospital, the flow of the main processes (logistical demands), the capacity needed and the existing buildings (conditions and capacity).

This planning process is shown in the illustration below:

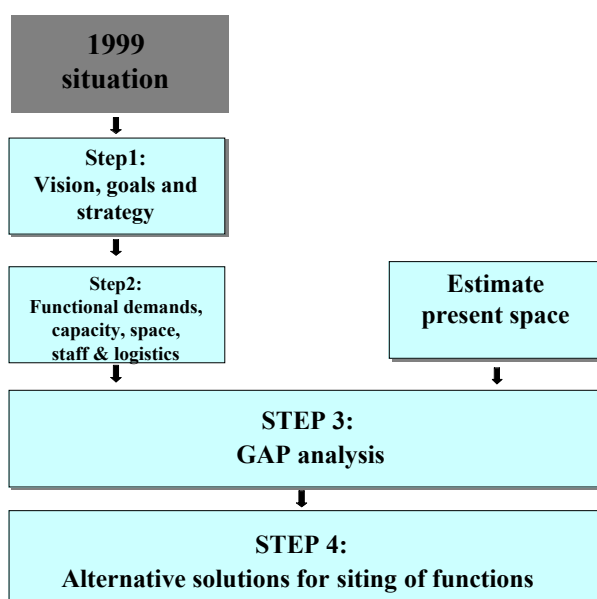

As shown the project is carried out in four steps:

1. A strategic plan with goals and visions for the new hospital (report from Ementor 04.01.2001), including an extrapolation of the patient volume for 2020 and some overall suggestions for physical locations of the different functions.
2. An estimation of the present space and a theoretical calculation of the future space needed. Plus an estimation of the staff needed in 2020. (This report) The future space and the staff need is calculated on the basis of the future patient volume stated in step 1 and the present space is stated from drawings and estimations made by the technical department at Landspitali.
3. A space gap analysis where the present space and the future needed space are compared in order to find the best possible solution for the main complexes of Landspitali.
4. Alternative solutions for localization of functions

The following illustration shows in overall terms the scope of this project the two circles representing the present project and the following phase, working with the investments and architectural planning.

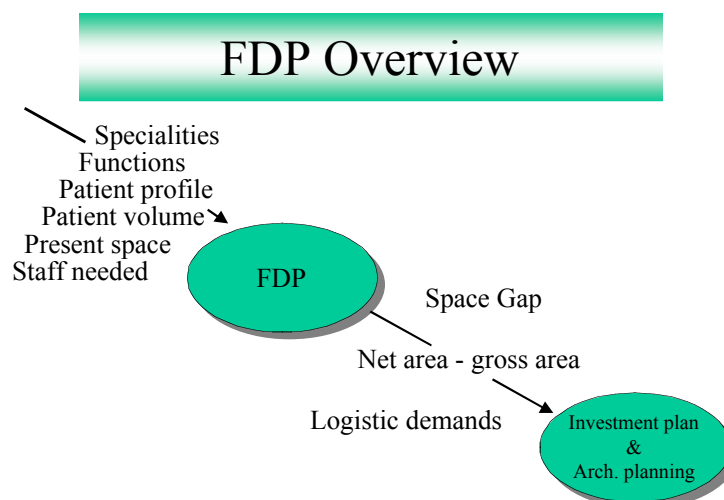

The analysis and results in this report are based on

- The Functional Development Plan, developed for SHR in 1999
- Step 1: The report on visions, goals and strategy, Ementor 04.01.2001
- Estimation of existing space in Hringbraut
- Staffing data for Landspitali in 1999

All calculations are presented in a separate appendices report.

2 Patient Profile and Volume

As already described in the report from 04. January 2001 Ementor has extrapolated the patient volume to 2020. These data has been further elaborated with some new information and with some minor adjustments and are therefore shown in this report again in order to provide the reader a total picture of the methods used here.

The following illustration shows the extrapolation in two steps.

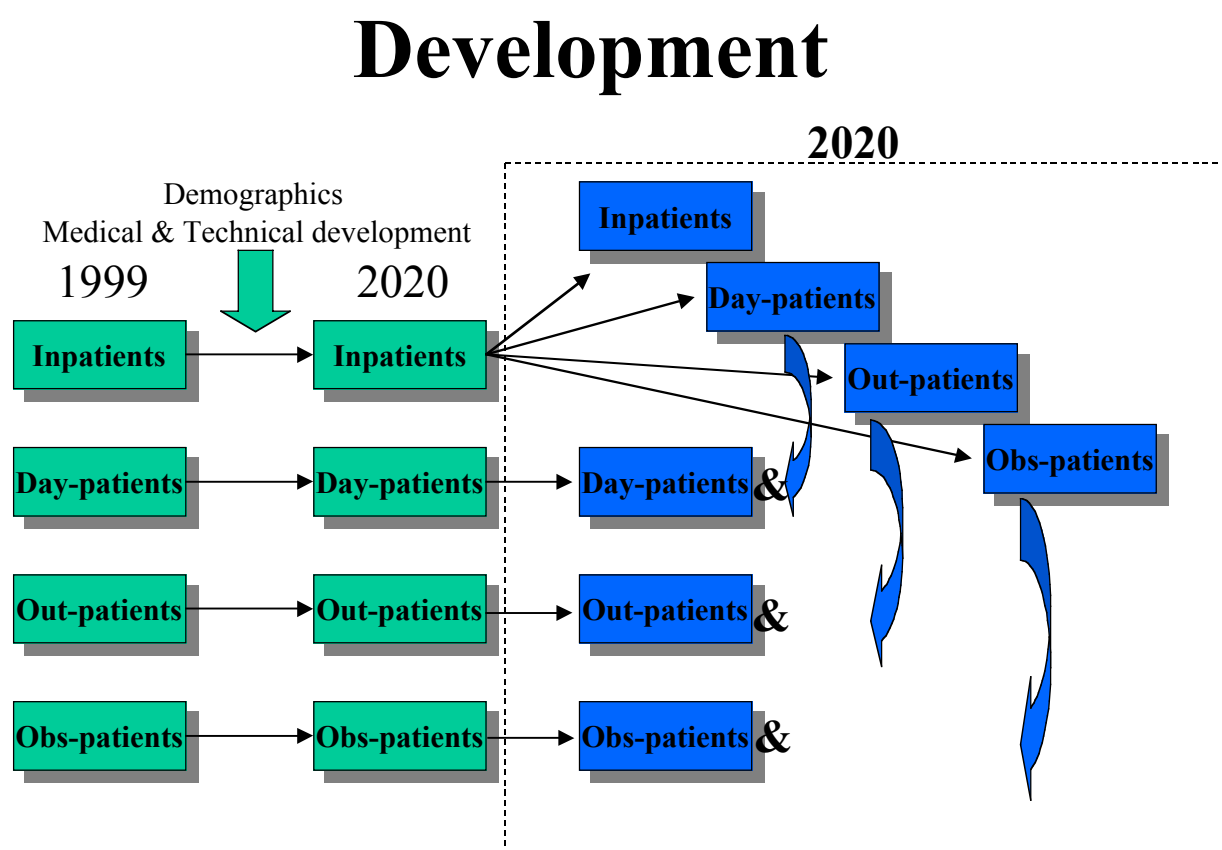

Step one is a simple extrapolation due to the demographic development. The fact that more and more citizens move into Reykjavik as well as the general population development has been taken into account (36% for somatic and 11% for psychiatry). But the development as to a higher number of elderly people in the population has not been taken into account.

Step two is a more advanced extrapolation where the inpatients are moved to a lower grade of care (from bed to chair). We base this recommendation on the trends that are seen in the Scandinavian hospitals – and other European hospitals – where patients are transferred from in-patient care to day care and/or outpatient care. We also recommend that some of the long-term patients be moved out of the two buildings into other houses e.g. Grensás or Kopavogur in order to let the main buildings contain only acute functions.

In Appendix 1 and 2 of this report the updated version of both steps in the extrapolation is shown.

Some of the figures have been further qualified. The differences in the calculations is as follows:

- one inpatient now is converted into an average of 1,5 day patient + 1 out patient visit (previously 2 day pat. and one out pat.)
- an observation patients has a LOS of 1,0 bed days (previously 1,5 bed days).

We recommend that an observation unit as seen in both Hringbraut and Fossvogi today – also in the future will be used as a “gate keeper” function for the wards.

We recommend that this unit be enlarged in order to prevent a lager number of patients from being admitted to the traditional wards and to ensure a quicker diagnostic and treatment services.

In the following calculations we look at the collective patient volume in the two complexes Hringbraut (incl. Eiriksgata and Torfinnsgata) and Fossvogur. The suggested movements of specialties (from step 1 report) have also been taken into account. This means that we now refer to a total Hringbraut & Fossvogur

- Incl. acute neurology, dermatology, venerology, pulmonology, and allergic diseases
- Exc. rehabilitation and long term beds and long term geriatrics

2.1 Inpatients 2020

Ementor recommends increasing day and outpatient care, as well as observation care, and at the same time reducing number of in-patients in the different sub-specialties as follows

Division	Admissions 2020 simp.ex	Transferred to Day care		Transferred to Obs. Unit		Remaining admissions ⁴⁾
General pediatrics	3309	662	20%	993	30%	1654
Neonatology	510	0	0%	0	0%	510
Pediatric surgery	1635	409	25%	327	20%	899
Total pediatrics	5453	1070	20%	1320	24%	3063
Obstetrics	4948	1237	25%	990	20%	2721
Gynecology	1417	354	25%	283	20%	779
Total gyn/obs	6364	1591	25%	1273	20%	3500
Gen. int. medicine	900	180	20%	270	30%	450
Gastroenterology	801	160	20%	240	30%	401
Dermatology ¹⁾	229	46	20%	0	0%	183
Cardiology	4000	800	20%	1200	30%	2000
Rheumatology	1003	201	20%	301	30%	502
Nephrology	195	39	20%	59	30%	98
Pulmonary & allergical dis. ¹⁾	2334	467	20%	700	30%	1167
Endocrinology	190	38	20%	57	30%	95
Infection	968	0	0%	290	30%	678
Neurology ²⁾	1248	250	20%	0	0%	999
Total Internal medicine I	11869	2180	18%	3118	26%	6571
Oncology + Hematology	1486	297	20%	0	0%	1189
Total Internal medicine II	1486	297	20%	0	0%	1189
Gen. surgery	3922	980	25%	784	20%	2157
Vascular	336	0	0%	0	0%	336
Urology	1495	374	25%	299	20%	822
Plastic surgery	328	82	25%	0	0%	246
Ophthalmology	305	76	25%	0	0%	229
Orthopedics	2649	662	25%	530	20%	1457
ENT	1160	290	25%	0	0%	870
Neurosurgery	1282	0	0%	256	20%	1026
Thoracic surgery	455	0	0%	0	0%	455
Total surgery	11933	2465	21%	1870	16%	7599
Geriatrics	558					558
TOTAL SOMATIC	37664	7604	20%	7580	20%	22481
PSYCHIATRY	1567	313	20%	313	20%	940
GRAND TOTAL	39231	7917	20%	7893	20%	23421

¹⁾ Inclusive today's numbers from Vífilsstaðir/Verholt

²⁾ Inclusive today's numbers from Grensas

³⁾ These patients will get their LOS reduced with 3 as they are transferred to units outside F&H

⁴⁾ Admissions from simple extrapolation minus the ones transferred to day care unit and to observation unit.

2.2 LOS 2020

As for the length of stay (LOS), the future conditions can be calculated in various ways. We chose to let the future LOS to be determined by the house with the best practice. This means that we have used the lowest LOS of the specialties that today is located in both complexes. For those specialties that are located in one place the LOS has been used directly, except for geriatrics where a maximum LOS of 14 days is recommended. Since this is an acute hospital we find it reasonable that patients admitted longer than 14 day are transferred to other locations. Please see appendix 1, page 1 – LOS marked with a shade.

The groups of patients transferred to day care/out patient clinic and the observation unit are more “light” in the sense of length of stay. This means that a new LOS for 2020 will have to be longer than the ones of today. To see the calculation for LOS 2020, please see at appendix 2, page 4 and 5 or the above table.

2.3 Day patients 2020

At the same time as the number of inpatients decreases the total number of appearances of day patients will increase. In the following table the future total number of day patients in 2020 is shown.

Division	Day-patients			
	Appearances 1999	Increase in app 2020 - simp.ex.	Increase in appearances from inpatients	Day patient appearances 2020
General pediatrics ¹⁾	1.908	678	993	3.579
Neonatology	0	0	0	0
Pediatric surgery	0	0	613	613
Total pediatrics	1.908	678	1.606	4.192
Obstetrics	5.976	2.125	1.855	9.956
Gynecology	2.186	777	531	3.494
Total gyn/obs	8.162	2.902	2.387	13.451
Gen. int. medicine	1.051	374	270	1.695
Gastroenterology	115	41	240	396
Dermatology	0	0	69	69
Cardiology	766	272	1.200	2.238
Rheumatology	81	29	301	411
Nephrology	3.631	1.291	59	4.981
Pulmonary & allergical dis.	146	52	700	898
Endocrinology	8	3	57	68
Infection	20	7	0	27
Neurology	7	2	375	384
Total Internal medicine I	5.825	2.071	3.270	11.167
Oncology + Hematology	2.530	900	446	3.875
Total Internal medicine II	2.530	900	446	3.875
Gen. surgery	550	196	1.471	2.216
Vascular	0	0	0	0
Urology	231	82	561	874
Plastic surgery	11	4	123	138
Ophthalmology	1.116	397	114	1.627
Orthopedics	238	85	993	1.316
ENT	440	156	435	1.032
Neurosurgery	0	0	0	0
Thoracic surgery	8	3	0	11
Re-visit from ER ¹⁾	0	0	0	0
Total surgery	2.594	922	3.697	7.213
Geriatrics	0	0	0	0
Rehabilitation / long term	0	0	0	0
Total medicine	8.355	2.971	3.716	15.042
SOMATIC	21.019	7.474	11.406	39.898
PSYCHIATRY	6.045	690	3.133	9.868
GRAND TOTAL	27.064	8.164	14.539	49.766

For all inpatients transferred to day care we have calculated 1_ appearances per patient.

2.4 Outpatients 2005

At the same time as the numbers of inpatient decreases and the number of day patients increases, the total number of visits to the out patient clinic will increase. In the following table the future total number of out patients in 2020 is shown.

Division	Outpatient clinic			
	Outpat. clinic visit 1999	Increase of outpatient visits simp.ex	Increase due to increase in day patients	Outpat. clinic visits 2020
General pediatrics ¹⁾	11.536	4.102	496	16.134
Neonatology		0	0	0
Pediatric surgery		0	307	307
Total pediatrics	11.536	4.102	803	16.441
Obstetrics	14.271	5.074	928	20.273
Gynecology	5.480	1.948	266	7.694
Total gyn/obs	19.751	7.023	1.193	27.967
Gen. int. medicine	8.884	3.159	135	12.178
Gastroenterology	3.860	1.372	120	5.353
Dermatology	21.126	7.512	34	28.672
Cardiology	19.075	6.782	600	26.457
Rheumatology	225	80	150	455
Nephrology	0	0	29	29
Pulmonary & allergical dis.	2.621	932	350	3.903
Endocrinology	4.928	1.752	28	6.709
Infection	639	227	0	866
Neurology	2.452	872	187	3.511
Total Internal medicine I	63.810	22.688	1.635	88.133
Oncology + Hematology	14.895	5.296	223	20.414
Total Internal medicine II	14.895	5.296	223	20.414
Gen. surgery	3.508	1.247	735	5.491
Vascular	0	0	0	0
Urology	4.270	1.518	280	6.069
Plastic surgery	0	0	62	62
Ophthalmology	4.223	1.502	57	5.782
Orthopedics	9.054	3.219	497	12.770
ENT	8.405	2.988	218	11.611
Neurosurgery	91	32	0	123
Thoracic surgery	0	0	0	0
Re-visit from ER ¹⁾	14.406	5.122	0	19.528
Total surgery	43.957	15.629	1.849	61.435
Geriatrics	0	0	0	0
Rehabilitation / long term	0	0	0	0
Total medicine	54.202	19.272	1.858	75.332
SOMATIC	153.949	54.738	5.703	214.390
PSYCHIATRY	20.059	2.290	1.567	23.915
GRAND TOTAL	174.008	57.028	7.269	238.305

This table is exclusive of the first visit of emergency patients. Ementor have suggested that the revisits from ER were moved out of the hospital into the primary health care system, but this option has been evaluated to be impossible at the present time.

2.5 Summary of patient transfer

The present way of financing the health care system in Iceland does actually not support this transfer from inpatient to day patient status. But due to our experiences from other countries, e.g. as mentioned Norway, where the same complex of problems is known, Ementor will maintain the above stated suggestions as a way of “stressing” the system in order to persuade the financial system to follow.

In order to show the total ratio of transfers the following illustration shows the figures in a total.

Movements of patients from 1999 to 2020.

	1999	2020	Difference	Difference in %
Inpatients	29.191	23.421	-5.770	-24,6%
LOS	5,7	7,1	1,4	19,9%
Beddays	166.561	166.871	310	0,2%
<i>Observation pat.</i>	<i>4.800</i>	<i>14.421</i>	<i>9.621</i>	<i>66,7%</i>
In pat + Obs pat.	33.991	37.842	3851	10,2%
Beddays incl obs pat.	171.361	188.502	17141	9,1%
LOS incl. obs pat.	5,0	5,0	-0,1	-1,2%
Day patients appear.	27.064	49.766	22.702	45,6%
Out pat. visits	174.008	238.305	64.297	27,0%
Normal	159.602	218.777	59.175	27,0%
Re-visits	14.406	19.528	5.122	26,2%

3 Estimation of the Staff volume 2020

In this chapter the analysis and an estimation of the future staff volume for year 2020 will be stated.

The used staff model will be described using the present staff volume and activities to calculate the future staff needed based on the future activities as described in chapter 2 above.

3.1 The staffing model

3.1.1 Input to the model

The input for the model can be split into three areas: Activity data (patients), the present staff data and preconditions for the standards used in the model.

- The activity data is based on the present patient data from LSH in 1999/2000 and the extrapolated figures for the patient activity at Landspítali in 2020 (appendix 2). The difference between 1999 and 2000 has been evaluated and no significant changes have occurred.
 - The patient activity data includes number of inpatients and bed days, number of day patients, observation patients, and number of visits to the outpatient clinics. In addition to this the number of diagnostic imaging examinations.
- Staff volume from 2000 for both Hringbraut and Fossvogur (appendix 3). The data in the model have been divided into doctors including one department director for each department and other staff including the other director of that department. The figures have been provided by the HR function of Landspítali.
- The preconditions for the calculation are based on re-estimated bed days and admissions in 1999. The estimations are:
 - Day patients and observation patients are recalculated into admissions with a factor 1/3 admission
 - Outpatient clinic visits are recalculated into admissions with a factor 1/12 admission
 - Day patients and observation patients are recalculated into bed days with a factor 2 bed days
 - Outpatient clinic visits are recalculated into bed days with a factor _ bed day

3.1.2 Calculations in the model

From the input data the model will calculate the re-estimated number of admissions and bed days for each department and as a total. In addition a number of productivity data is calculated, e.g. inpatients/bed day per employee in each department, this is used to estimate some key figures.

By choosing a set of productivity standards for 2020 and feeding the model with the extrapolated figures for 2020 it will calculate an estimate of the future staff volume for 2020. The suggested number of staff for 2020 can be evaluated by comparing it for similar departments with those of 1999.

In the model two alternatives for calculating the future staff in 2020 is shown.

- Model A: a calculation of the future staff volume based on unchanged productivity standards in 2020 compared to 1999/2000, e.g. one doctor treats as many patients as today.
- Model B: a calculation of the future staff volume based on a higher productivity in the clinical functions. The calculation is based on a simple comparison to a number of other hospitals in the Scandinavian region. Furthermore the merger between Reykjavík Sjúkhus and the previous Landspítali is bound to reduce some of the overlapping functions e.g. in the service departments.

For both alternatives it is important to look at this, as an overall calculation thus the future staff volume should not be considered as “correct” for at each department. We would like to emphasize that this is not an exact method and we are fully aware of the fact that this can not be used for determination of needed staff for individual departments. E.g. that nursing has more specific ways of calculating staff needs for the purpose of estimating their part of the staffing and thus this method can only be used as a rough estimate. But it is important to have this estimation in order to be able to calculate the need space for e.g. offices, meeting rooms, staff service etc. A very important factor of this analysis is to ensure that all the data of different hospitals has been registered in the same manner.

In the following the two calculations are described.

3.2 Clinical functions

The doctors' work is dependent on how many patients he and her have to treat and this goes for both inpatients, day patients and outpatients. For all other staff groups (which mainly is nurses and secretaries) workload will be more dependent on the length of stay (number of bed days).

For the clinical departments the model will calculate

- The total number of weighted patients per doctor in 1999 and weighted bed days per other employee in 1999.

3.2.1 Model A – unchanged productivity (the 1999-level is kept unchanged)

In model A we use the same productivity-standards in 2020 as in 1999/2000. On the basis of the number of weighted patients and bed days in the clinical departments the model will calculate the new number of employees for 2020.

We assume that there in 2000 was collective staff of Fossvogur and Hringbraut of 251 FTE doctors and 739 FTE others for the somatic clinical functions. For psychiatry there was 39 doctors and 70 others.

In model A (with unchanged productivity) the model will calculate a need for 320 doctors (256 for somatic and 54 for psychiatry) in year 2020. Equally a total of 1,046 others is calculated.

3.2.2 Model B – improved productivity inspired by benchmarking

In model B standards for 2000 has been benchmarked with other somatic departments in Scandinavia, mostly Norway and one hospital in Denmark. The hospitals that are included in the benchmarking is as follows:

- Sykehuset Østfold (Østfold) 1999
- Telemark Sentralsykehus (Telemark) 1998
- Kolding Sygehus (Kolding) 1999/2000
- Nordland Sentralsykehus (Nordland) 1998
- Vest-Agder Sentralsykehus
- Sentralsykehuset i Rogeland
- Regionsykehuset i Trondheim RIT 2000

In the tables below the result of this benchmarking is shown. Best practice for each specialty is marked with a yellow color. Please note that it has been necessary to look at some of the specialties in a more overall manner in order to make the data comparable. This also indicates that this method only can give us some indications for where to look for improvements in the matter of staff efficiency.

Benchmarking of weighted patients per doctor and weighted bed days per other staff

Benchmarking - standard staff	Weighted patients per doctor								
	LSH	SiA	Østfold	Telemark	Kolding	Nordland	Vest-Agder	SIR	RIT 2000
Total medicine	188	220	241	186	242	145	259	192	179
Total surgery	155	162	214	195	195	232	265	198	205
Gynecology/obstetrics	472	437	303	353	190	250	407	370	317
Pediatrics	186	144	191	271	183	158	274	194	158
Ophthalmology	136	-	317	-	-	282	212	246	213
Psychiatry	128	-	109	53	-	-	160	-	-

Benchmarking - standard staff	Weighted bed days per other staff								
	LSH	SiA	Østfold	Telemark	Kolding	Nordland	Vest-Agder	SIR	RIT 2000
Total medicine	529	188	327	237	368	238	373	249	262
Total surgery	255	251	301	281	320	258	333	313	335
Gynecology/obstetrics	337	207	285	-	276	240	256	286	231
Pediatrics	273	156	266	228	181	137	205	178	148
Ophthalmology	277	-	469	-	-	296	711	709	478
Psychiatry	631	-	196	-	-	-	242	-	-

Benchmarking of inpatients per doctor and per other staff

Benchmarking - standard staff	Inpatients per doctor								
	LSH	SiA	Østfold	Telemark	Kolding	Nordland	Vest-Agder	SIR	RIT 2000
Total medicine	100	162	176	133	169	112	195	169	140
Total surgery	109	118	149	143	133	160	189	144	146
Gynecology/obstetrics	247	331	221	278	140	189	298	286	230
Pediatrics	134	110	155	209	150	135	248	164	121
Ophthalmology	33	-	62	-	-	110	75	50	86
Psychiatry	36	-	42	53	-	-	57	-	-

Benchmarking - standard staff	Inpatients per other staff								
	LSH	SiA	Østfold	Telemark	Kolding	Nordland	Vest-Agder	SIR	RIT 2000
Total medicine	45	25	40	25	37	26	47	38	28
Total surgery	32	33	38	41	37	34	45	34	38
Gynecology/obstetrics	38	36	44	34	42	36	37	39	33
Pediatrics	40	18	40	38	28	21	34	25	18
Ophthalmology	12	-	17	-	-	24	49	25	32
Psychiatry	20	-	4	3	-	-	4	-	-

Benchmarking of day patients per doctor and per other staff

Benchmarking - standard staff	Day care per doctor								
	LSH	SiA	Østfold	Telemark	Kolding	Nordland	Vest-Agder	SIR	RIT 2000
Total medicine	82	92	52	62	132	21	54	-	-
Total surgery	19	54	47	22	67	40	48	35	28
Gynecology/obstetrics	430	87	49	88	24	51	98	52	-
Pediatrics	64	25	13	109	-	2	-	1	-
Ophthalmology	163	-	389	-	-	297	83	194	135
Psychiatry	155	-	149	-	-	-	144	-	-

Benchmarking - standard staff	Day care per staff								
	LSH	SiA	Østfold	Telemark	Kolding	Nordland	Vest-Agder	SIR	RIT 2000
Total medicine	36	14	12	12	29	5	13	-	-
Total surgery	6	15	12	6	19	9	12	8	7
Gynecology/obstetrics	67	10	10	11	7	10	12	7	-
Pediatrics	19	4	3	20	-	-	-	-	-
Ophthalmology	59	-	106	-	-	65	54	97	51
Psychiatry	86	-	14	-	-	-	11	-	-

Benchmarking of outpatient visits per doctor and per other staff

Benchmarking - standard staff	Outpatient clinic per doctor								
	LSH	SiA	Østfold	Telemark	Kolding	Nordland	Vest-Agder	SIR	RIT 2000
Total medicine	768	345	524	412	363	318	577	285	496
Total surgery	503	337	568	568	495	735	740	539	612
Gynecology/obstetrics	1040	973	816	567	527	552	963	826	1083
Pediatrics	385	315	394	322	409	271	329	376	457
Ophthalmology	616	-	1593	-	-	936	1377	1653	1036
Psychiatry	514	-	224	-	-	-	700	-	-

Benchmarking - standard staff	Outpatient clinic per other staff								
	LSH	SiA	Østfold	Telemark	Kolding	Nordland	Vest-Agder	SIR	RIT 2000
Total medicine	342	53	119	79	80	73	140	64	100
Total surgery	149	95	147	164	139	158	176	128	160
Gynecology/obstetrics	162	107	162	68	159	105	120	113	155
Pediatrics	114	52	102	59	76	41	45	56	70
Ophthalmology	222	-	434	-	-	204	893	827	389
Psychiatry	287	-	22	-	-	-	53	-	-

In the following table the number of weighted patients per doctor and weighted bed days per others are shown again with a clear indication of best practice and *the chosen standards* for calculating the staff need for LSH 2020 (Bold, Italic and with a higher font).

Benchmarking of weighted patients per doctor and weighted bed days per other staff

Benchmarking - standard staff	Weighted patients per doctor								
	LSH	SiA	Østfold	Telemark	Kolding	Nordland	Vest-Agder	SIR	RIT 2000
Total medicine	188	220	241	186	242	145	259	192	179
Total surgery	155	162	214	195	195	232	265	198	205
Gynecology/obstetrics	472	437	303	353	190	250	407	370	317
Pediatrics	186	144	191	271	183	158	274	194	158
Ophthalmology	136	-	317	-	-	282	212	246	213
Psychiatry	128	-	109	53	-	-	160	-	-

Benchmarking - standard staff	Weighted beddays per other staff								
	LSH	SiA	Østfold	Telemark	Kolding	Nordland	Vest-Agder	SIR	RIT 2000
Total medicine	529	188	327	237	368	238	373	249	262
Total surgery	255	251	301	281	320	258	333	313	335
Gynecology/obstetrics	337	207	285	-	276	240	256	286	231
Pediatrics	273	156	266	228	181	137	205	178	148
Ophthalmology	277	-	469	-	-	296	711	709	478
Psychiatry	631	-	196	-	-	-	242	-	-

	Weighted patients per doctors			Weighted beddays per other staffs		
	LSH 1999	LSH 2020	Ændr.	LSH 1999	LSH 2020	Ændr.
Total medicine	188	241	28%	529	529	0%
Total surgery	155	232	50%	255	313	23%
Gynecology/obstetrics	472	472	0%	337	337	0%
Pediatrics	186	194	5%	273	273	0%
Ophthalmology	136	282	108%	277	709	156%
Psychiatry	128	128	0%	631	631	0%

The following standards has been chosen for LSH in 2020:

- Medicine I+II: 241 weighted patients per doctor (Østfold) and 529 weighted bed days per others (Landspitali). For the first standard actually Vest-Agder has the best practice but in order to be more moderate we chose Østfold as the standard.
- Total surgery excl. eye: 232 weighted patients per doctor (Nordland) and 335 weighted bed days per others (RIT2000). Again for the first standard actually Vest-Agder has the best practice but in order to be more realistic we chose Nordland as the standard, which is an improvement of 50% for LSH. This is due to the fact that there in LSH is a high potential for improving the efficiency in the surgical departments. We know there is a rather low rate of day surgery and also there is the possibility to split the elective and acute patients in order to get a higher efficiency.
- Gynecology and obstetrics: 472 weighted patients per doctor (LSH) and 337 weighted bed days per others (LSH), which are the present standards in LSH.
- Pediatrics: Here again Vest-Agder has the best practice with 274 weighted patients per doctor, but we recommend SIR 194, which is very close to the present situation in LSH. For others the best practice is LSH with a standard of 273 weighted patients.
- Eye: with 317 weighted patients per doctor Østfold have best practice but we have chosen a standard of 282 from Nordland. 711 weighted bed days per others (Vest-Agder) is the best practice but we have chosen 709 (SIR). The figures indicate that there are an improvement potential of about 100%.
- Psychiatry. The present standards at LSH are kept also in 2020. 128 weighted patients per doctor (Vest-Agder has a standard of 160) and 631 weighted bed days per others.

3.2.3 Comparison of model A and B

In the following table the calculations of model A and B is shown and compared with the 2000 staffing

Comparison of the staff need for the clinical functions in 2000 and 2020 model A & B

Clinical functions	Staffs 2000			Staffs 2020 - unchanged standards Model A			Staffs 2020 - Model B		
	Doctors	Other staffs	Total	Doctors	Other staffs	Total	Doctors	Other staffs	Total
Total medicine	103	230	333	117	283	400	91	283	374
Eye (ophthalmology)	7	19	26	9	26	35	4	10	15
Total surgery, excl. ophthalmology	79	267	346	88	336	424	59	255	314
Gynecology/obstetrics	19	122	141	22	168	189	22	168	189
Pediatrics	30	101	131	31	136	167	30	136	165
Total gyn/obs.	49	223	272	53	303	356	51	303	355
Total somatic	237	739	976	266	949	1.215	206	852	1.058
Psychiatry	39	70	109	54	97	151	48	97	145
Clinical functions	276	809	1.085	320	1.046	1.367	253	949	1.203

3.3 Clinical service functions and other service functions

Likewise we have calculated two models for the clinical and non-clinical service functions. For some of the functions a more detailed benchmarking has been carried out: OR/ICU/Anesthetics, Radiology and Laboratories. The total calculation can be seen in details in appendix 4.

Benchmarking of weighted surgical patients per doctor (anesthesiologist) and weighted bed days per other staff for Anesthesiology/OR and ICU

Benchmarking	Weighted surgery patients per doctor (anesthesiology)						
	LSH 1999	SiA 1998	Østfold 1999	Telemark 1998	Kolding 1999	SIR 1999	RIT2000 1998
Anesthesiology/OR/intensive	303	627	489	-	421	-	595

Benchmarking	Weighted surgery patients per other staff						
	LSH 1999	SiA 1998	Østfold 1999	Telemark 1998	Kolding 1999	SIR 1999	RIT2000 1998
Anesthesiology/OR/intensive	90	60	39	-	54	-	63

Benchmarking the number of examinations in radiology per doctor and examinations per other staff

Benchmarking	Number of examinations in radiology per doctor						
	LSH 1999	SiA 1998	Østfold 1999	Telemark 1998	Kolding 1999	SIR 1999	RIT2000 1998
Radiology & diag. image	9.291	7.513	8.006	5.046	8.241	6.721	6.552

Benchmarking	Number of examinations in radiology per other staff						
	LSH 1999	SiA 1998	Østfold 1999	Telemark 1998	Kolding 1999	SIR 1999	RIT2000 1998
Radiology & diag. image	3.179	1.908	1.733	1.159	2.032	1.890	1.404

Benchmarking of weighted patients per staff (doctors and others) for the laboratories

Benchmarking	Weighted patients per staff					
	LSH 1999	SiA 1998	Østfold 1999	Nordland 1998	SIR 1999	RIT2000 1998
Total laboratory	151	245	366	181	219	181

Benchmarking	Number of staff					
	LSH 1999	SiA 1998	Østfold 1999	Nordland 1998	SIR 1999	RIT2000 1998
Total laboratory	312	151	155	118	215	269

In the table below a comparison of the two models A and B are shown for both clinical service functions and non-clinical service functions.

Cross service functions	Staffs 1999			Staffs 2020 - unchanged standards Model A			Staffs 2020 - Model B			
	Doctors	Other staffs	Total	Doctors	Other staffs	Total	Doctors	Other staffs	Total	
Anesthesiology/OP/intensive	37	125	162	43	145	188	27	145	172	
Radiology & diag. image	13	38	51	18	52	69	18	52	69	
Pharmacy	0	36	36	0	41	41	0	41	41	
Emergency/acute reception	19	99	118	21	111	132	21	111	132	
Occupational- and physiotherapy	5	58	63	6	75	81	6	75	81	
Total laboratory	32	280	312	36	299	335	-	-	215	
Medical record archives etc.	0	9	9	0	10	10	0	8	8	
Social workers	0	29	29	0	37	37	0	26	26	
Various service departments	0	994	994	0	1.284	1.284	0	895	895	
Engineering, architect, incl. adm.	0	270	270	0	349	349	0	243	243	
Priest	0	5	5	0	6	6	0	5	5	
Student	0	60	60	0	78	78	0	54	54	
Total cross service functions	106	2.003	2.109	124	2.488	2.612	1	72 ²	1.654	1.941

1) Excl. doctors in the laboratory functions

2) Excl. other staffs in the laboratory functions

3.4 Staffing 2020

In total the two models are shown in the following table.

	Staffs 1999			Staffs 2020 - unchanged standards Model A			Staffs 2020 - Model B			
	Doctors	Other staffs	Total	Doctors	Other staffs	Total	Doctors	Other staffs	Total	
Total clinical functions	276	809	1.085	320	1.046	1.367	253	949	1.203	
Total cross service functions	106	2.003	2.109	124	2.488	2.612	72	1.654	1.941	
Landspitali (V+H) in total	383	2.812	3.195	445	3.534	3.979	1	325 ²	2.603	3.144

1) Excl. doctors in the laboratory functions

2) Excl. other staffs in the laboratory functions

By using the above stated standards for LSH the total sum of employees for 2020 will be 3,144.

4 Clinical Functions in 2020

The calculation of number of beds needed in 2020 for patient wards, day care unit, intensive care unit, etc. is based on a utilization rate of the bed as well as the future bed days as shown in the previous chapters.

4.1 Patient wards

We suggest that the beds could become a common resource for all specialties in the hospital. This means in more practical terms, that some beds are mainly dedicated to specialized surgical functions and some to medical, but that there is a rather broad overlapping zone between the departments, as it is known today with oncology and hematology at Fossvogur and nephrology and urology at Hringbraut. There will still be a need for specialized beds for psychiatry, children, obstetrics, monitored beds for cardiac patients etc.

To estimate the number of beds needed in the future, we have to decide a bed occupancy rate on utilization term of references.

- For the utilization % of beds: Ementor suggest 85 %, which is the “normal” efficiency goal for the use of hospital beds in Scandinavia.

Based on our suggestions for future in-patient activity, we estimate the number of beds needed in 2020 as follows:

- Internal Medicine, including all sub-specialties (Int. medicine I + Medicine II): 191 beds including 25 beds for cardiac monitoring. (Today 192 beds)
- Surgery, including all sub-specialties: 158 beds (today 195 beds)
- Geriatrics 26 beds (today 25 beds)
- Women and Children 119 beds (today 140 beds)
- Psychiatry 58 beds (today 69 beds)

Besides the above we suggest increasing the number of beds for observation to 47 beds. These observation beds can be used up to max. 48 hours per patient.

The intensive care unit at Fossvogur is quite new with 11 beds. At Hringbraut there are 8-10 beds in the ICU. We suggest intensive care beds in the future LSH (18 beds) to be co-used with the recovery beds (14 beds), for cross-functional use of anesthetic and nursing staff. This could also include the cardiac intensive beds.

4.2 Day patient services

We suggest gathering all functions for day patients in three units to achieve the most efficient use of the day capacity.

This could mean – depending of the location of functions -

- One day hospital for all medical specialties
- One day hospital for all surgery
- One for obstetrics located together with other obstetric functions
- One for pediatrics located together with other pediatric functions
- One for psychiatry located together with other psychiatric functions

From the day hospital the patients will go to diagnostics and treatments in the special diagnostic functions (e.g. urology, gastrolaboratory, x-ray, surgery). This means that LSH could benefit from locating the day hospital and the outpatient clinics very close together.

Therefore Ementor recommend placing these units closely together in order to increase flexibility, also in the future, and to share patients, equipment and staff.

Based on the suggested future day activity we estimate the number of day-beds/chairs to be

- Internal medicine I +II: 66 beds/chairs
- Surgery, incl. gynecology and children: 50 beds/chairs
- Obstetrics: 44 beds/chairs
- Pediatrics: 16 beds/chairs
- Psychiatry: 43 beds/chairs

4.3 Out-patient services and specialized diagnostic services

Outpatient services can be organized in different ways:

- one area covering all out-patient functions with ordinary reception and waiting area for all specialties in the hospital
- each specialty has its own out-patient clinic located close to the ward, and where the same staff moves between ward and out-patient clinic

But as mentioned above Ementor recommends to keep all the clinics together and to locate the clinics in connection with the entrance area for walking patients. The clinics should as mentioned be closely together with the day care unit and with easy access to Radiology and other special diagnostic service.

In LSH there are several specialized diagnostic functions serving in-patients, day patients and outpatients e.g.:

- Urology: urodynamic and cystoscopy
- Oncology: Radiotherapy
- Gastro laboratory: endoscopic services
- Clinical physiology: spirometry, cardiac testing etc.
- HBO - Hyper Baric Oxygen Treatment
- Neurophysiology examinations, e.g. EEG, EMG etc.
- Gynecology: Ultrasound, embryo diagnostics, IVF etc.
- Psychiatry: e.g. light therapy, etc.

These functions could - if possible – to some extent be gathered in order to achieve synergy and cross-functional use of staff (nursing, administration) and space.

4.4 Offices and meeting rooms

The office area consists of offices for leading doctors, nurses and other leaders. Normally in Scandinavian hospitals an office location/desk is assigned to all doctors and other academic staff. Also all administrative staff needs an office location/desk. Meeting rooms are estimated from precondition that one third of all personnel working during daytime (70%) must be able to be in a meeting at the same time.

In this project we have calculated with two different room standards for offices:

- One space standard (10 m² per office unit) is used for the executive staff and staff in the administration
- A lower space standard (8 m² per office unit) for doctors, academic staff, secretaries etc.

The lower standard is based on a high rate of shared offices, e.g. as mobile offices in landscape.

5 Clinical Service Functions in 2020

5.1 Emergency department

Only emergency patients and patients for acute admissions should come through emergency. All others such as elective admissions, outpatients and day-patients etc. will go directly to the relevant department.

The emergency department or departments receives the following patients:

- Trauma patients for emergency care and treatment, patients who thereafter are transferred to operational theatres, intensive care, cardiology unit etc.
- Emergency patients for out-patient-treatment who can leave the hospital after treatment
- Patients for acute admission preferably in the observations unit within the emergency department, alternatively transferred to intensive care, cardiology unit or wards

The emergency department also has special units for rape-victims and intoxicated patients.

Ementor suggests that the observation unit is strengthened in order to save a larger number of patients a traditional admission in the wards. Based on our estimations for the future activities, we suggest that a patient can stay in the observation unit up to 2 days, with an average LOS of 1,0, which gives a total of 47 observation beds.

The ambulance services are performed by the local fire department and the coast guard performs the helicopter service. The emergency department assigns a doctor to follow the ambulance. All the ambulances and other vehicles and the necessary garages are placed in the fire department's building approx. 2 minutes away from both hospitals.

It is important only to have one area for the arriving ambulances per building.

5.2 Operational theatres

The operational theatres are presently located in both complexes on several different floors. The size of the individual theatres is very small compared to what is known as a reasonable size in a modern hospital. Some improvements seem mandatory to live up to the standards of today.

Some of the operational theatres must be placed with easy access from emergency and be located in close connection with intensive care and recovery. Some of the theatres should be reserved for elective operations in location close to the day units.

For some of the operational theatres that must serve both in-patient and day surgery the more simple and smaller size can still be reasonable. But as more and more complicated surgeries are possible as day surgery also this type of theatres requires more space. We have therefore in the future space for LSH calculated an average standard for the theatres of 120 m² in order to give some flexibility in the further planning of the theatres.

The future surgical activity is a consequence of the patient related activity, and the suggestions made by Ementor regarding moving patients from in-patient stay to day care. We have extrapolated the number of surgeries with 36% and moved all the transferred inpatients for inpatient surgery to day surgery.

The total extrapolation is shown in the tables below:

In patients

Specialty	Operation 1999 Inpatient	Increase from simple extrappl.	Decrease due to transfer to daysur. ¹	Operation 2020 Inpatient
General surgery/vascular	1.891	672	-980	1.583
Urology	1.346	479	-374	1.451
Neurosurgery	632	225	0	857
Ear, nose, throat	1.025	364	-290	1.099
Orthopedics	2.072	737	-662	2.147
Ophthalmology	312	111	-76	347
Thorax	306	109	0	415
Plastic surgery	611	217	-82	746
Pediatric	738	262	-409	592
Gynecology	884	314	-354	844
In total	9.817	3.491	-3.228	10.080

Day patients

Specialty	Operation 1999 Day patient	Increase from simple extrappl.	Increase due to transfer to daysur. ¹	Operation 2020 Day patient
General surgery/vascular	112	40	980	1.132
Urology	170	60	374	604
Neurosurgery	2	1	0	3
Ear, nose, throat	292	104	290	686
Orthopedics	130	46	662	838
Ophthalmology	783	278	76	1.138
Thorax	0	0	0	0
Plastic surgery	0	0	82	82
Pediatric	0	0	409	409
Gynecology	2.738	974	354	4.066
In total	4.227	1.503	3.228	8.958

¹⁾ Inpatients transferred to day surgery

Below a table shows the future number of operations and operational theatres in 2020. The number of theatres is conclusively 22 rooms, which are 7 rooms more than today (7 rooms in Fossvogur, 7 rooms in Hringbraut and 1 in Eiriksgata). The calculation made for 2001 shows a total number of 18 operation theatres, which are 3 more than the actual capacity.

Specialty	Operations 1999	Operations 2020	Operations daytime 80%/100%	Operations pr. day	Minutes	OP Hours pr. day	Calculated number of theatres	Suggested number of theatres
General surgery/vascular	1.891	1.583	1.266	5,51	120	11,01	1,38	2
Urology	1.346	1.451	1.161	5,05	120	10,09	1,26	2
Neurosurgery	632	857	685	2,98	90	4,47	0,56	1
Ear, nose, throat	1.025	1.099	879	3,82	90	5,74	0,72	1
Orthopedics	2.072	2.147	1.717	7,47	180	22,40	2,80	3
Ophthalmology	312	347	277	1,21	60	1,21	0,15	1
Thorax	306	415	332	1,44	170	4,09	0,51	1
Plastic surgery	611	746	597	2,60	120	5,19	0,65	1
Pediatric	738	592	473	2,06	100	3,43	0,43	1
Gynecology	884	844	675	2,94	80	3,92	0,49	1
Day surgery	4.227	8.958	8.958	38,95	90	58,42	7,30	8
In total	14.044	19.037	17.021	74	1220	130	16	22

5.3 Recovery, Intensive care and Anesthetics

At Fossvogur the intensive care has been renewed recently, the ward has 11 beds and will remain in close connection with recovery, which has 9 beds for adults and 4 for children. At Hringbraut there are 10 beds in the ICU on the same floor as recovery, with 11 beds, and the operation theatres.

With a simple extrapolation of the admitted patients in the ICUs with 36% and the same LOS as in 1999 2.8 days, the total number of beds in the ICU should be 18 in 2020. This means that there probably is an over-capacity in the ICUs at the present time. The table below shows the calculations for the ICU in 2020.

Department	Patients in 1999	Adm. days 1999	LOS 1999	Patients in 2020	Adm. days 2020	LOS 2020	Calculated number of beds	Suggested number of beds
Intensive	1311	3616	2,8	1783	4918	2,8	18,0	18

We suggest that in the future only inpatients will use the recovery beds as all day patients have their own day bed or chair. We assume that it will be possible to use these day beds as recovery from day surgery. The LOS for the inpatient in recovery is 3 hours. Thus the following calculation for the future need of recovery beds appears:

	Operations pr day	Average LOS in recovery	Hours pr day on recovery	Calculated number of beds	Suggested number of beds
Recovery	36,00	3	108,0	13,5	14,0

5.4 Radiology and diagnostic imaging

Radiology and diagnostic imaging is an important diagnostic tool. Generally we expect changes in the profile of services as follows

- More MR, CT, ultrasound diagnostics
- More intervention in diagnostic and treatment
- Less conventional X-ray examination

It is hard to know exactly how this development will go as far as year 2020. Therefore we have chosen to extrapolate the resulting number of all examinations with the 36% collectively and we suggest a total of 32 labs at LSH. In order to get a higher efficiency some of these should be restricted to the acute functions and some to the elective. The calculation is shown in the table below.

Examination type	Examinations 2020	-85% in daytime	Examinations pr. day	Minutes pr. exam.	Exam. hours pr. day	Calculated no. of labs	Suggested no. of labs ²
Radiology	163.734	139.174	605	25	252	31,5	32

5.5 Laboratory

LSH has a wide range of laboratory services within clinical biochemistry, microbiology, immunology, blood bank functions and pathology.

Laboratory service “on location” is an advantage for quick testing of in-patients and patients admitted through Emergency in a hospital. But we recommend that this will be done in a different way than today.

We suggest gathering all the laboratory functions in one place in order to get a more efficient use of equipment and staff etc. But at the same time we suggest building up smaller satellite stations for taking simple tests gathering samples etc. in order to provide a good service for all departments.

Order of tests and receiving results could be administrated and supported by e-mail or other information technology. The physical transportation of samples could be organized by having a dedicated shuttle bus between the satellite stations and the main laboratories with the necessary material.

5.6 Occupational and physiotherapy

Services like physio- and occupational therapy should be in close connection to the specialties using their services, like psychiatry, orthopedics, neurology, geriatrics etc. Therefore if possible Ementor suggest to integrate these service into the relevant wards or at least to locate their rooms very close by. This means transportation of staff instead of patients.

However, some functions will be centralized for all specialties (for instance some workout rooms).

5.7 Archives for Medical records and X-ray files

All hospitals are moving towards the electronic medical record and digital imaging (PACS).

However, we suggest assigning space for archiving, as this is not an issue at a present state. However, enlarging the archives will not encourage working more focused towards an electronic successor of the traditional records. We therefore suggest preserving records in some of the present rooms dedicated for this purpose and to move out records more than 3 years old to a remote archive in another location.

6 Education and university functions in 2020

At the new LSH the university and education functions has a high priority and must therefore be of some higher standard than today. In these functions there should be room for:

- Auditorium
- University functions for students
- Research facilities
- Medical library

6.1 Auditorium

We suggest establishing one large auditorium for approx. 400 seats used for special occasions, seminars, staff meetings etc.

6.2 University functions for students

Regarding the medical students we assume the following figures:

- There are 50 new medical students and 40 nursing students per year
- The medical students have 5 years studies and the nursing students 4 years, which means 250 medical students and 160 nursing students in total
- 60% of the official study time will take place in the hospital
- There are 40 active study weeks per year
- We assume 30 education hours per student per week in average, which means 410 students x 60% x 30 hours per week = 7380 student hours per week.
 - 20 % of the hours are spent in a smaller auditorium for all medical/nursing students per year
 - 40 % of the hours are spent in smaller group rooms (of 10 students)
 - 40 % of the hours are spent in the hospital departments: wards, outpatient clinics, laboratories etc.

In the following the calculations for the m² is shown for the different units:

Small auditorium

1,480 student hours per week, and 40/50 students per the room.

This gives 37 room hours per week, and requires two auditoriums of 50 seats.

We calculate with $1,5 \text{ m}^2$ per seat = 75 m^2 . In addition secondary rooms are needed (wardrobes, toilets, storage). Per Auditorium 100 m^2 , in total 200 m^2

Group rooms

2,950 student hours per week, and 10 students per room.

This gives 295 room hours per week, i.e. 10 group rooms of each 10 seats (30 hours per room per week)

Each room is 20 m^2 , which gives 200 m^2 in total for nine rooms.

Other facilities for student

Other facilities are dimensioned for 245 students in average (60%), and the facilities are

- Wardrobe: 245 units, in total 245 m^2
- Canteen used in three shifts, with 80 places. In total 160 m^2
- Social rooms 100 m^2
- Reading rooms for 30 % of the 205 students, 80 seats, in total 320 m^2

Other facilities amount to 825 m^2 .

In total the net square area in total for medical and nursing students is $1,225 \text{ m}^2$.

6.3 Research

The most important factor for the research is the number of university employees.

In Norwegian hospital there are approximately 0,7 FTE per medical student for teaching and research.

We have in average 150 medical students in the hospital, which means 105 university employees in the hospital for medical science.

For hospital staff, and that perform the nursing students we assume, that majority of hospital education the research activities are lower. We assume a ratio of 0.2 FTE per nursing student. This means 32 university employees in the hospital for nursing science.

In total we have 182 university employees, for which we assume:

- The major part of the university employees are academic/nursing staff, say 100 FTE's
- Each of these academic employees need an office of 10 m² and half of them also a research area of 10 m² per academic staff. In total 1500 m².
- The rest of the university staff needs 10 m² per FTE, 820 m².

This means that 2320 m² is needed for research in total.

6.4 Medical Library

Furthermore there is a need for a medical library of approx. 300 m².

7 Service Functions in 2020

7.1 Kitchen

At LSH there are kitchens in various locations, at Hringbraut, Fossvogi, Landakot and Arnarholt.

Ementor suggest only one kitchen, located in Hringbraut. The kitchen should serve all facilities in Reykjavik.

7.2 Administration

Most of the joint administration for the two complexes is placed in Eiriksgata and some of the technical administration located in Rauoarástigur. Only a few accounting and financial departments are still located at Hringbraut and Fossvogur. We suggest gathering all top management and administrative functions in one location.

7.3 Patient service

We suggest establishing some patient services in connection with the central entrance areas such as cafeteria, newsstand etc. We also suggest considering other patient services such as information, patient's representative, library with Internet connection etc.

7.4 Staff service

Staff services are mainly wardrobes and canteen. It is common standard today in a modern hospital that every employee without an office shall have his or her own locker and that all employees have access to a canteen. The wardrobes should be located near the working area, i.e. decentralized to the individual building complexes.

7.5 Other service functions

Other services are mainly related to supply services and transportation:

- Storage, distribution, garbage disposal
- Cleaning, sterilization
- Pharmacy services

All these services are in the complexes today, and we recommend having one main storage area for warehousing, clothes etc. and one centralized sterilization unit serving all hospital functions. Functions for distributions of goods and collection of waste must be available in both main complexes, as well as cleaning functions.

We suggest outsourcing the pharmaceutical services.

8 Determination of Future Space

8.1 Methodology

The future needs for space in the different departments is based on the estimated future, number of bed days, visits to the outpatient clinics, examinations etc., and the number of staff according to the previous chapters.

The calculation is also based upon a number of predefined coefficients of utilization and area standards for each function and/or specialty. The methodology for calculation of the future space is illustrated in the following figure.

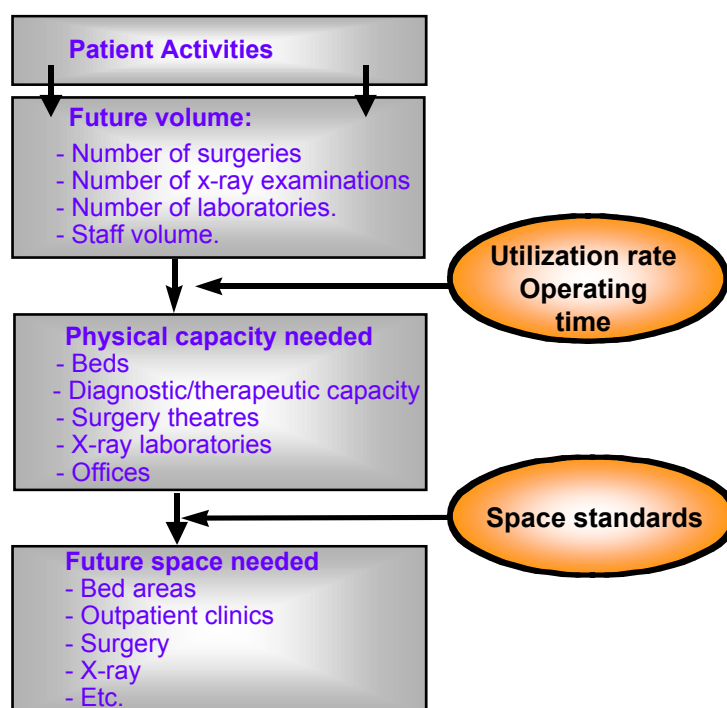

All areas are calculated as *Net areas in square meters*. Net areas are the total functional areas in a ward or department. The calculation adds up the inside measurements of each room. Thus the net areas are without walls, hallways, stairs, elevators, technical rooms for e.g. ventilation etc.

The gross areas are then all traffic areas, walls, hallways, elevators, stairs and technical areas

8.1.1 Utilization rate

The utilization rate represents the predefined percentages of occupancy per room or bed. The rate also shows the production time per visit, treatment or examination. In the following tables the suggested rates for LSH are shown.

Bed occupancy rate

	Utilization days/year
Beds	
Normal somatic beds	85%
Normal psychiatric beds	85%
Intensive care beds	75%
Observation beds	85%

These suggestions have been chosen as a result of looking at the present ratios at LSH and comparing them to other recent hospital projects in Scandinavia.

In order to give an equal comparison of the different utilization rates chosen for this project we have listed some selected average rates below.

The table compares the present rates (where we have them) and the future suggested rates for LSH with some reference rates taken from the new region hospital in Trondheim, Norway, RIT 2000 and the new Østfoldsykehuset in Norway.

Function	Present occupancy rate SHR	Occupancy rate future LSH	Hours per day future LSH	Occupancy rate Østfold sykehuset	Hours per day Østfoldsy kehuset	Occupancy rate RIT 2000	Hours per day RIT 2000
Somatic beds	72%	85%		85%		85%	
Psychiatric beds	88%	85%		85%			
Intensive care	52%	75%		75%		98%	
Observation		85%	24	70%	8/24	70%	
Day beds		-	6	-	6	-	6
Outpatient clinic		-	7	-	6	-	6
Radiology		-	8	-	7	-	6
Surgery, theatres		-	8	-	7	-	6

The present rates are very different from department to department on the somatic beds. The above shown figures are an average of all departments. The present rate for observation, outpatients, radiology and surgery are not known as we need to know the exact number of beds / rooms used for each function to be able to calculate this. For intensive care 19 (11 + 8) beds have been used. As can be seen from the above stated figures we have chosen some very competitive rates for LSH.

In the table below the different rates for examinations and treatments in the various departments are shown. These figures are equally based on experience from recent projects in Norway, Østfold and RIT 2000.

Utilization per function

	Days/year	Hours/day		Min. pr. examination/treatment
Daypatients				
Day beds	230		¹⁾	1 visit pr. day-patient
Outpatient clinics				
Medicine	230	7	¹⁾	45
Surgery and Orthopedics	230	7	¹⁾	30
Psychiatry	230	7	¹⁾	75
Radiology and diag. imaging (planned)				
Radiology average	230	8	¹⁾	25
Operations (planned) & Recovery				
Orthopedics	230	7	¹⁾	180
General surgery	230	7	¹⁾	120
Urology	230	7	¹⁾	120
ENT	230	7	¹⁾	90
Ophthalmology	230	7	¹⁾	60
Plastic Surgery	230	7	¹⁾	120
Gyn/obs	230	7	¹⁾	80
Children	230	7	¹⁾	100
Thoracic surgery	230	7	¹⁾	170
Neurosurgery	230	7	¹⁾	180
Vascular surgery	230	7	¹⁾	140
Day surgery	230	7	¹⁾	90
Recovery beds (inpat.)	230	7	¹⁾	Average LOS 3 hours
Emergency				
Acute Outpatient clinic	365	8		45
Emergency	365	8		60

¹⁾ 230 = workdays (one year excl. weekends, holidays, etc.)

8.1.2 Space standards

The space standard refers to the primary rooms such as bed wards, examination and treatment rooms, office's, etc., and includes secondary rooms such as restrooms, storage's, tea-kitchens etc. See appendix 4.

All the standards, e.g. a standard for an outpatient room of 30 m², include both primary and secondary rooms. The standard represents an average, meaning that the exact size of each room and the number of secondary rooms can be varied during the later detailed planning of each department.

An example: For the outpatient room standard of 30 m², the first 20 m² is used for the primary examination and treatment room and the rest, the remaining 10 m², represents this room's part of patient areas, storage, room for cleaning service, staff areas, toilets etc.

In the following table a list of the suggested space standards for this project is shown together with comparable figures from Østfold and RIT2000.

	Landspítali	Østfold	RIT 2000
	Standards m ² net.	Standards m ² net.	Standards m ² net.
Clinical functions			
Beds (somatic)	21	26	24
Cardiac monitoring beds & neonatology beds	30	30	30
Beds (psychiatry)	31	36	-
Day beds (somatic)	15	15	15
Day beds (psychiatry)	20	20	-
Outpatient rooms	30	32	32
Special rooms for outpatients (somatic)	40	50	50
Special rooms for outpatients (psychiatry)	30	30	-
Observation beds	21	26	24
Delivery rooms	70	70	70
Clinical service functions			
Intensive care beds	40	40	39
Emergency	50	50	50
Recovery	15	15	14
Operation	120	120	90-120
Radiology & Diag. Image.	90	90	90
Service functions			
Offices management/head of depart. + adm.	10	10	10
Offices other doctors and academic personnel	8	9	10
Meeting rooms	1,7	1,7	1,7
Sleeping quarters/on call duty	15	15	50-70 1
Dress rooms	1	1	1
Canteen	2	2	1,3

1) Sleeping quarters per center

8.2 Theoretical space estimations

The result of the space demands is a manifestation of a theoretical calculation. And because in reality the departments and functions must fit into an existing frame of buildings the actual apportion between the departments and functions must be reviewed in a later state during the process of detailed programming.

Thus this calculation lays out a framework within which the proceeding work of rebuilding and re-organizing LSH can take place. For this purpose we have calculated a short-term estimation 2001 and a long-term estimation 2020 for the space needed at Hringbraut and Fossvogur.

As mentioned in the previous chapters the estimations are based upon a number of predetermined standards and utilization rates. E.g. in this project the space standard for a somatic bed is predefined to be 21 m². This is based on the theory that the beds are located in bed pools of 25 beds each, sharing secondary facilities for patients, staff and supply. An example of a detailed calculation is shown in the table below.

Somatic	
Bed pool - 25 beds	
15 sqm pr. bed (average incl. bath/WC) (1)	375
Storage (medicine 4 sqm, clean 5 sqm, unclean 4 sqm, linen 4 sqm, equipment 8 sqm)	25
Disinfection room 10 sqm, cleaning 5 sqm.	15
1 examination room 15 sqm, 1 conversation room 8 sqm	23
Staff room (tea-kitchen & day room 12 sqm, toilet 2 sqm)	14
Expedition (head of dept. nurse 10 sqm, secretary and on call rooms 15 sqm)	25
Kitchen	15
Patients day room (1 sqm pr. patient incl tea-kitchen)	25
Total	517
Net. sqm. pr. bed	21
(1) e.g. 5 single-bedrooms of 15 sqm , 10 double bedrooms of 25 sqm	325
10 Sanitary rooms of each 5 sqm. (one pr single room and one pr 2 double rooms)	50

In the same way a calculation for psychiatric beds has been done, this is shown in the next table.

Psychiatry	
Bed pool - 25 beds	
18 sqm pr. bed (average incl. bath/WC) (1)	450
Storage (medicine 6 sqm, linen 6 sqm, equipment 10 sqm)	22
Activation, group therapy (4 sqm. pr. pat.)	100
Laundry for patients	20
1 examination room 15 sqm, 2 conversation room 8 sqm	31
Staff room (tea-kitchen & day room 14 sqm, toilet 3 sqm)	17
Expedition (head of dept. nurse 10 sqm, secretary and on call rooms 15 sqm)	25
Workstations (2 x 8sqm)	14
Kitchen	20
Patients day room (3 sqm pr. patient incl tea-kitchen)	75
Total	774
Net. sqm. pr. bed	31
(1) e.g. 25 single-bedrooms of 13 sqm	325
25 Sanitary rooms of each 5 sqm.	125

In the following table a space calculations for 2001 and 2020 are shown for all the main functions within the hospital. To preserve the overview, the functions are divided into four overall groups:

- Clinical functions
- Medical service functions
- Education and university functions
- Non-medical service functions

	2001 needs		2020 needs		Change from 2001 to 2020	
	net m ²	gross m ²	net m ²	gross m ²	net m ²	in %
Bedwards for somatics	10.101		10.513		412	3,9%
Bedwards for psychiatry	2.232		1.798		-434	-24,1%
Day care for somatics	1.410		2.640		1.230	46,6%
Day care for psychiatry	540		860		320	37,2%
Outpatient clinic	3.640		4.390		750	17,1%
Emergency/acute reception	640		740		100	13,5%
Observation beds	357		987		630	63,8%
Delivery beds	630		630		0	0,0%
Part result	19.550		22.558		3.008	13,3%
Intensive care	560		720		160	22,2%
OP	2.160		2.640		480	18,2%
Recovery	210		210		0	0,0%
X-ray	2.160		2.880		720	25,0%
Lab	3.516		3.706		190	5,1%
Occ + physio	800		800		0	0,0%
Pharmacy	500		500		0	0,0%
Part result	9.906		11.456		1.550	13,5%
Offices + meeting rooms	9.362		9.722		360	3,7%
University & education	2.320		5.045		2.725	54,0%
Archives	300		300		0	0,0%
Wardrobes/canteen/sleeping quart.	3.872		3.929		57	1,4%
Patient service	1.543		1.648		105	6,4%
Supplies & maintenance ¹	6.300		6.300		0	0,0%
Part result	23.697		26.944		3.247	12,0%
Primary Healthcare	260		260		0	0,0%
Total area	53.413	105.470	61.218	120.881	7.805	12,7%
Gross/Net factor	1,97		1,97			

As shown the total space is calculated 53.413 m² for 2001 and 61.218 m² for 2020. This means that from today 2001 until 2020 the need for space theoretically will increase with approx. 7.800 m² (or 12,4%). All the details of the calculation are shown in Appendix 8 and 10.

For 2001 the only “change” from the previous situation in the hospital is that we calculate with a more effective laboratory service and a decrease of staff of 5% in the administration.

9 Determination of Present Space

The present space has been determined from building drawings provided by the technical department of Landspítali (Fossvogur and Hringbraut).

The present space of Fossvogur has already been determined in our previous work (Functional Development Plan for Fossvogur from 22.12.1999) and has now for this purpose been slightly modified. The present space of Hringbraut consists of many different smaller buildings and includes property on Eriksgata, Torfinnsgata, Rauðarárstígur, and the new children's hospital.

In order to make the figures comparable with the calculations of future needs per function (see chapter 8.2), we have divided the different functions into small fractions on each floor of each building. This is due to the fact that mainly the service functions are spread across the hospital as it is today.

The offices are mostly included in the same wings and floors as the departments. These have to the highest possible level been extracted from the ward areas in order to determine the present space per function. Because of the fragmentation and the natural integration of the functions in the present environments of the wards, the present space is vitiated by some uncertainty on the functional level.

This is primary due to the fact that some functions are not completely separated; e.g. if the sleeping quarters for the doctors are integrated into office areas or other secondary rooms of a bed ward, and have therefore not been registered as staff service. Secondary the net area is not a normal parameter on building drawings, and thus it has been a challenge to calculate the exact net square meters of each function on the basis of the official drawings.

9.1 Presentation of the present space - Fossvogur

The complex at Fossvogur is divided into five buildings A, B, C, E/F and G.

Both A and B has today seven floors plus basement. The E/F wing has seven floors plus basement. The top floor is new on this wing, and has recently been taken into use.

The C wing is the tower located between the A/B and E wings. On the first seven floors this building have mainly functions as Hallway, room for elevators and stairs some meeting rooms and offices. From the 8th floor and up to the 13th floor, the C wing is used for offices (management and accounting) and the hospital library. The top floor (the 14th floor) is not used presently due to the fact that it is not accessible from the inside. Because of the space required for elevators and staircase there is rather few "functional" square meters on each floor in the C wing.

The G wing has three floors of which the first is in level with the basement of the E wing. The Emergency department is placed on the second floor of the G wing, which is in ground level and thus has entrances for ambulances and patients arriving with helicopter.

The proportional locations of the wings are shown below.

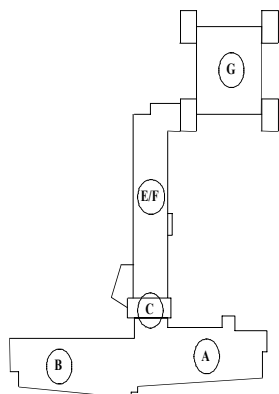

In order to find the right net area of the wings the areas has been divided according to their functions.

This is shown in the table below with each function represented by a different color.

	M ² Net	M ² Gross	No of beds/ rooms 1999	Net sqm. perr unit
Bedwards for Somatics	2969		215	13,81
Bedwards for Psychiatry	557		24	23,19
Day care	193		20	9,64
Outpatient clinic	1106			
Emergency/acute reception	339			
Observation beds	80		8	9,99
Part result	5243			
Intensive care	564			
OP	1012			
Recovery	104		11	9,46
X-ray	730		9	81,11
Lab	868		13	66,77
Occ + physio	359		11	32,60
Pharmacy	215			
Part result	3852			
Offices + meeting rooms	1871			
University & education	123			
Archives	239			
Wardrobes/canteen/sleeping quart.	616			
Patient service	356			
Supplies & maintenance ¹	2772			
Part result	5978			
New Floor	616			
Total area	15688	29263		
Gross/Net factor	1,87			

The total gross area of the hospital is 29,263 m² and the total net area is calculated to be 15,688 m². This gives a Gross/Net factor of 1.87.

The gross/net factor is usually somewhere between 1.75 and 2.0, so this sounds very reasonable.

In some of the square meters stated on the technical drawings of the hospital the inner walls were included. As in fact the walls can represent a significant number of m², the space has been reduced accordingly.

The factor, by which we have reduced the given net areas, has been calculated individually for each building. Appendix 6 shows the split of functions per floor in each building and the reductions made due to hallways etc. in details.

9.2 Presentation of the present space – Hringbraut

The complex at Landspítali, Hringbraut, is divided into different buildings in different areas. First we have the main area with building 1 as the main complex divided into eight wings: A, B, C, D, W, E, F, G and K.

Further more there are nine buildings inside the complex of Hringbraut: building 2, 3, 6/7, 8, 9, 10/11, 13, 14 and 16 plus there are six other buildings separated from the main areas in the nearby areas: Torfinnsgata 14-16, Eriksgata 5, 19, 21 & 29 and Raudarárstigur. In addition comes the new children's hospital. Building 12 is not taken into account since it is going to be demolished in the near future.

An overview of the complex is shown below.

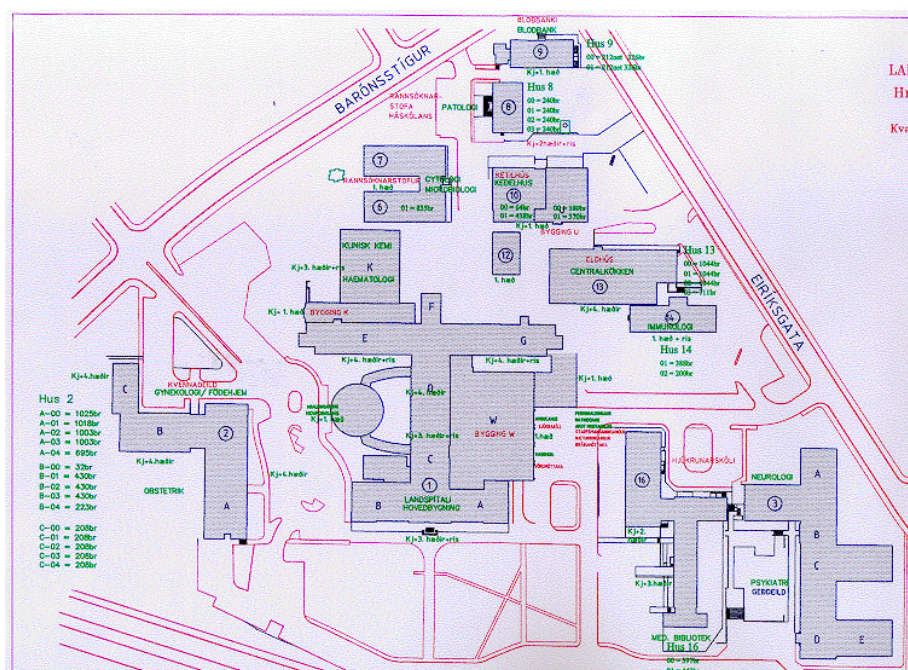

A more detailed drawing of the main buildings (1, 2 and 3) is shown below.

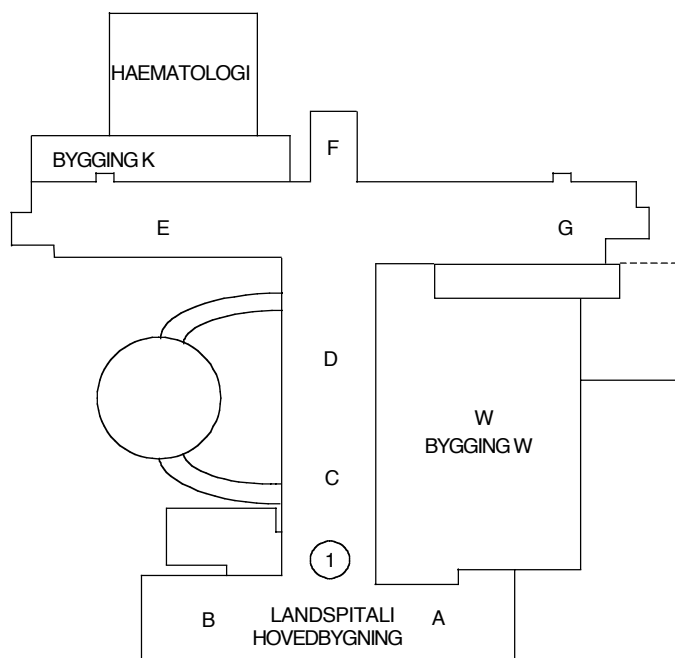

Building 1

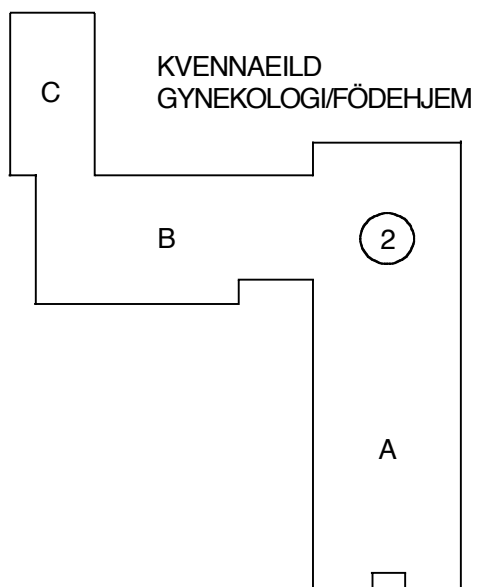

Building 2

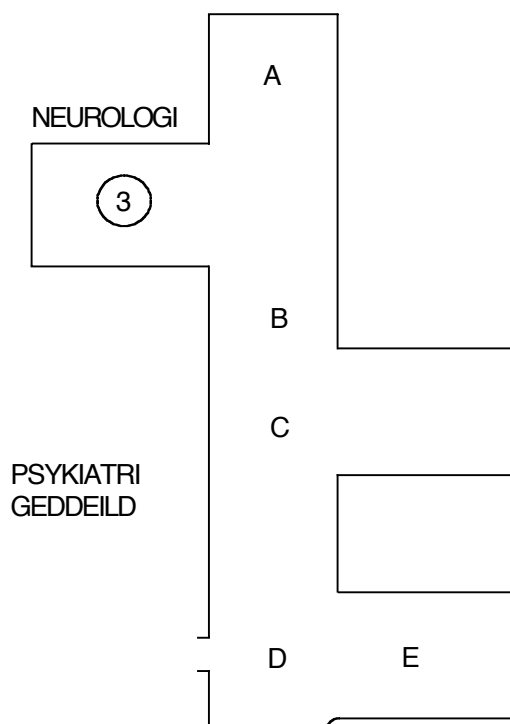

Building 3

In order to find the right net area of the buildings, the space has been divided according to their functions like it was done in Fossvogur. This is shown in the table below with each function represented by a different color.

	M ² Net	M ² Gross	No of beds/ rooms 1999	Net sqm. per unit
Bedwards for Somatics	4899	9459	334 ^a	14,67
Bedwards for Psychiatry	1113	2181	60	18,56
Day care	544	1044		
Outpatient clinic	2207	4568		
Emergency/acute reception	549	1070		
Observation beds	154	299	16	9,65
Delivery beds	205	391	6	34,20
Part result	9672	18621		
Intensive care	283	547	11	25,68
OP	654	1559		
Recovery	248	480		
X-ray	546	1057		
Lab	1552	2557		
Occ + physio	978	1556		
Pharmacy	155	300		
Part result	4416	8055		
Offices + meeting rooms	6959	12154		
University & education	618	981		
Archives	185	356		
Wardrobes/canteen/sleeping quart.	968	1554		
Patient service	1001	1935		
Supplies & maintenance ¹	2301	9904		
Part result	12032	26882		
New Childrens hospital	3579	6800		
Total area	29699	60359		
Gross/Net factor	2,03			

The total gross area of the hospital is 60,359 m² and the total net area is calculated to 29,699 m². This gives a Gross/Net factor of 2.03, which is a little high but very likely to correspond with the actual situation. The gross/net factor is usually somewhere between 1.75 and 2.0, but since there are many “extra” square meters used because of the numerous small buildings this sounds very reasonable.

Appendix 7 shows the split of functions per building in details.

9.3 Total present space

In the following table the total space of the two complexes are shown.

	Fossvogur		Hringbraut		Landspítali	
	net m ²	gross m ²	net m ²	gross m ²	net m ²	gross m ²
Bedwards for Somatics	2.969		4.899		7.868	
Bedwards for Psychiatry	557		1.113		1.670	
Day care	193		544		737	
Outpatient clinic	1.106		2.207		3.313	
Emergency/acute reception	339		549		888	
Observation beds	80		154		234	
Delivery beds	0		205		205	
Part result	5.243		9.672		14.915	
Intensive care	564		283		847	
OP	1.012		654		1.666	
Recovery	104		248		352	
X-ray	730		546		1.276	
Lab	868		1.552		2.420	
Occ + physio	359		978		1.337	
Pharmacy	215		155		369	
Part result	3.852		4.416		8.268	
Offices + meeting rooms	1.871		6.959		8.830	
University & education	123		618		742	
Archives	239		185		424	
Wardrobes/canteen/sleeping quart.	616		968		1.584	
Patient service	356		1.001		1.357	
Supplies & maintenance ¹	2.772		2.301		5.074	
Part result	5.978		12.032		18.010	
New Floor/Childrens hospital	616		3.579		4.195	
Total area	15.688	29.263	29.699	60.359	45.387	89.622
Gross/Net factor	<i>1,87</i>		<i>2,03</i>		<i>1,97</i>	

This shows a total net area for LSH of approx. 45,400 m² and a gross area of approx. 89,600 m²

10 Gap Analysis

In order to illustrate the problems of locating the future functions within the existing building frame a gap analysis has been made on the main functions of the hospital.

The present space has been calculated and divided according to the same model, as we have calculated the space needed for 2001 and 2020, please see chapter 8.2. The future space has been calculated as stated in the previous chapter and can be found in total in appendix 8.

10.1 Gap 1 - 2001

The first gap shows the present space compared to the theoretical calculated space for 2001. This calculation is based on the activities today (1999/2000) without transferring inpatients to day care, observation beds etc.

	Total present space		2001 needs		GAP 1	
	net m ²	gross m ²	net m ²	gross m ²	net m ²	in %
Bedwards for somatics	7.868		10.101		-2.233	-28,4%
Bedwards for psychiatry	1.670		2.232		-562	-33,7%
Day care for somatics	737		1.410		-673	-91,4%
Day care for psychiatry	0		540		-540	-100,0%
Outpatient clinic	3.313		3.640		-327	-9,9%
Emergency/acute reception	888		640		248	27,9%
Observation beds	234		357		-123	-52,4%
Delivery beds	205		630		-425	-207,0%
Part result	14.915		19.550		-4.635	-31,1%
Intensive care	847		560		287	33,9%
OP	1.666		2.160		-494	-29,6%
Recovery	352		210		142	40,4%
X-ray	1.276		2.160		-884	-69,3%
Lab	2.420		3.516		-1.096	-45,3%
Occ + physio	1.337		800		537	40,2%
Pharmacy	369		500		-131	-35,4%
Part result	8.268		9.906		-1.638	-19,8%
Offices + meeting rooms	8.830		9.362		-532	-6,0%
University & education	742		2.320		-1.578	-212,8%
Archives	424		300		124	29,2%
Wardrobes/canteen/sleeping quart.	1.584		3.872		-2.288	-144,5%
Patient service	1.357		1.543		-186	-13,7%
Supplies & maintenance ¹	5.074		6.300		-1.226	-24,2%
Part result	18.010		23.697		-5.688	-31,6%
New buildings	4.195		260		3.935	93,8%
Total area	45.387	89.622	53.413	105.470	-8.026	-17,7%
Gross/Net factor						

It shows a total gap of 8,000 m², mostly on the clinical functions and the non-medical service functions.

As can be seen from the above figures a direct and uncritical realization of this space would require a significant enlargement of the existing building frame. Somewhere in the amount of approx. $8,000 * 1.97 \text{ m}^2 = 15,500 \text{ m}^2$ keeping the same gross/net factor of 1.97 as the average of the two buildings today.

In chapter 11 we show how this gap can be closed due to a suggestion for a short-term solution for Hringbraut and Fossvogur.

10.2 Gap 2 - 2020

The second gap shows the lack of space between the present situation and the calculated future situation 2020. In this solution all the above stated pre-assumptions has been used e.g. demographic development, transfer of in patient care to day care, observation etc plus model B of the staff volume estimations.

	Total present space		2020 needs		GAP 2	
	net m ²	gross m ²	net m ²	gross m ²	net m ²	in %
Bedwards for somatics	7.868		10.513		-2.644	-33,6%
Bedwards for psychiatry	1.670		1.798		-128	-7,7%
Day care for somatics	737		2.640		-1.903	-258,4%
Day care for psychiatry	0		860		-860	-100,0%
Outpatient clinic	3.313		4.390		-1.077	-32,5%
Emergency/acute reception	888		740		148	16,7%
Observation beds	234		987		-753	-321,3%
Delivery beds	205		630		-425	-207,0%
Part result	14.915		22.558		-7.643	-51,2%
Intensive care	847		720		127	15,0%
OP	1.666		2.640		-974	-58,4%
Recovery	352		210		142	40,4%
X-ray	1.276		2.880		-1.604	-125,7%
Lab	2.420		3.706		-1.286	-53,1%
Occ + physio	1.337		800		537	40,2%
Pharmacy	369		500		-131	-35,4%
Part result	8.268		11.456		-3.188	-38,6%
Offices + meeting rooms	8.830		9.722		-892	-10,1%
University & education	742		5.045		-4.303	-580,2%
Archives	424		300		124	29,2%
Wardrobes/canteen/sleeping quart.	1.584		3.929		-2.345	-148,1%
Patient service	1.357		1.648		-291	-21,4%
Supplies & maintenance ¹	5.074		6.300		-1.226	-24,2%
Part result	18.010		26.944		-8.934	-49,6%
New buildings	4.195		260		3.935	93,8%
Total area	45.387	89.622	61.218	120.881	-15.831	-34,9%
Gross/Net factor						

Even so a gap of approx. 16.000 net m² has been determined. Compared to the first gap the university functions has become enlarged and so has some of the medical service functions e.g. day care, outpatient care, OR and Radiology.

11 Logistical demands for the future

11.1 General principles

This chapter will elaborate on some of the overall principles of the logistics within LSH taking into account the present situation - strengths and weaknesses. The overall logistical principles described below correspond to those sets up in the Functional development plan for LSH.

We will focus on the priority of mutual relationship and physical localization of the different clinical functions and some of the medical service functions on what could be known as the principles of vicinity or neighborhood between functions.

The physical placement of the functions will have to meet the requirements of mutual use/utilization of space and/or personnel. Also the localization should give the patients a logical flow to and from the hospital as well as during their admission.

Firstly a list of the most urgent demands and overall logistical principles that will assure an efficient patient flow and other transport flows to, from, and within the hospital.

The emphases on the external access to Fossvogur and Hringbraut should be as follows:

- Walking patients who need to go to the outpatient clinic, day care unit, or elective admission as well as visitors for the hospital should have one and only one entrance through a main lobby. From the main lobby there should be an easy overview of and logical access to the rest of the hospital.
- Bed laying patients, which comes through emergency, must have only this one entrance, which must be separated from entrances for other patients, personnel or supplies.
- Bed laying patients that comes as elective patients should also have only one entrance, in reality the ambulance entrance.
- Walking patients that comes to emergency without referral from any doctor should have a separate entrance to the ER. Ideally these patients should also use the main entrance of the hospital.
- The employees should have entrances reasonably close to their working area. This often means that there are several entrances for the personnel, but it is important that these are not the same used by the patients and visitors.
- Supplies should also only have one truck-area where trucks can have access to the storage areas, eventually through different entrances for storage, food and laundry. A separate entrance for waste collections is necessary.

The emphases on the internal logistic, which means the flow of patients, personnel and supply should be as follows:

- Walking patients can find their way easy in terms of good signs, colors, landmarks or other indicators that gives the patients and visitors a constant sense of where they are and where to go.
- Patients that are transported in beds should be aloud to move in shielded areas.
- Patients that are transported in beds should never be moved through the basement.
- Internal department corridors should only be used for internal transportation, and not for transportation of patients and staff between departments
- Supplies should be transported as far as possible in the basement and only in smaller amounts through the usual department corridors.

Overall principle must be taken into consideration for both building complexes.

The logistical problems of Fossvogur mainly relate to the number of entrances for patients, the location and spread of the main functions in the building, that internal corridors are used for main traffic purposes, the difficulties with orientation in the building.

In the following illustration all patient entrances are shown.

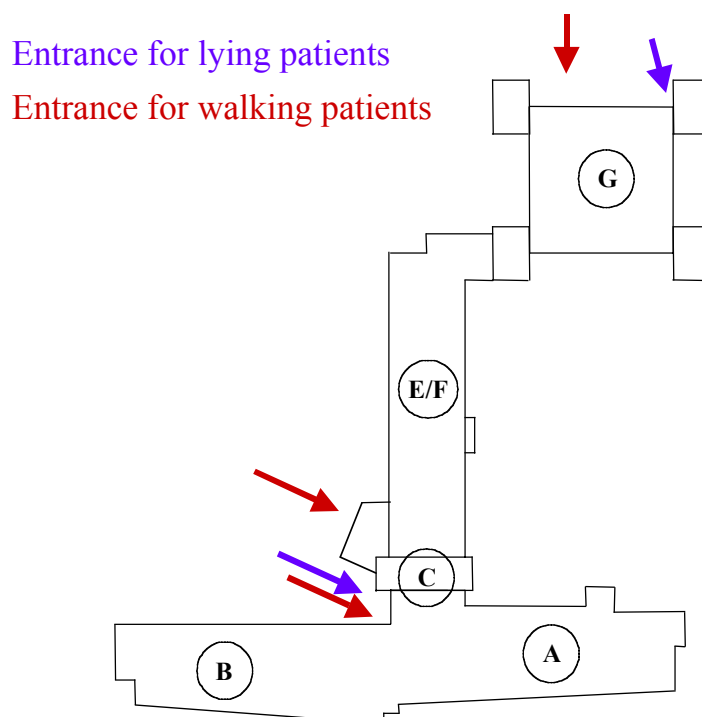

Hringbraut have in principle the same problems as Fossvogur, and in addition to that a very inhomogeneous building complex. There are a great number of smaller building, add-on buildings of variable quality, a poor traffic system and very little space between and around the buildings. Staffs also use the entrances for walking patients, and the ambulance entrance is just near supply and waste entrances.

Some photos taken at the hospital can illustrate this situation.



The first picture shows one of the small add-on buildings. This one is used by the radiologists for offices and meeting rooms. The second picture is from the main entrance of building 1. This entrance should be used by most walking patients and visitors, but unfortunately they prefer other entrances e.g. on the other side of the building shown in the pictures below.



In these photos the ambulance road and entrance are shown. Furthermore trucks and smaller private cars use this traffic corridor for ambulances. As can be seen in the upper right picture the ambulance entrance is very close to the entrance for deliveries of goods (food, materials,

cloth etc.) and just around the corner (lower left picture) is the exit for garbage disposal. The small entrance to the right of the ambulance entrance is used for both walking patients and staff. The entrance is shown closer on the lower right picture previous page.

On this page the ambulance entrance and the smaller entrance for walking patients and staff is shown from the inside. This hallway does as the matter of the fact work as the main corridor in building 1.



In the picture below building 3 (psychiatry) and building 16 (university) is shown, a good example of the closeness of the buildings at Hringbraut.



The entire entrance and traffic system for building 1 is shown in the figure below.

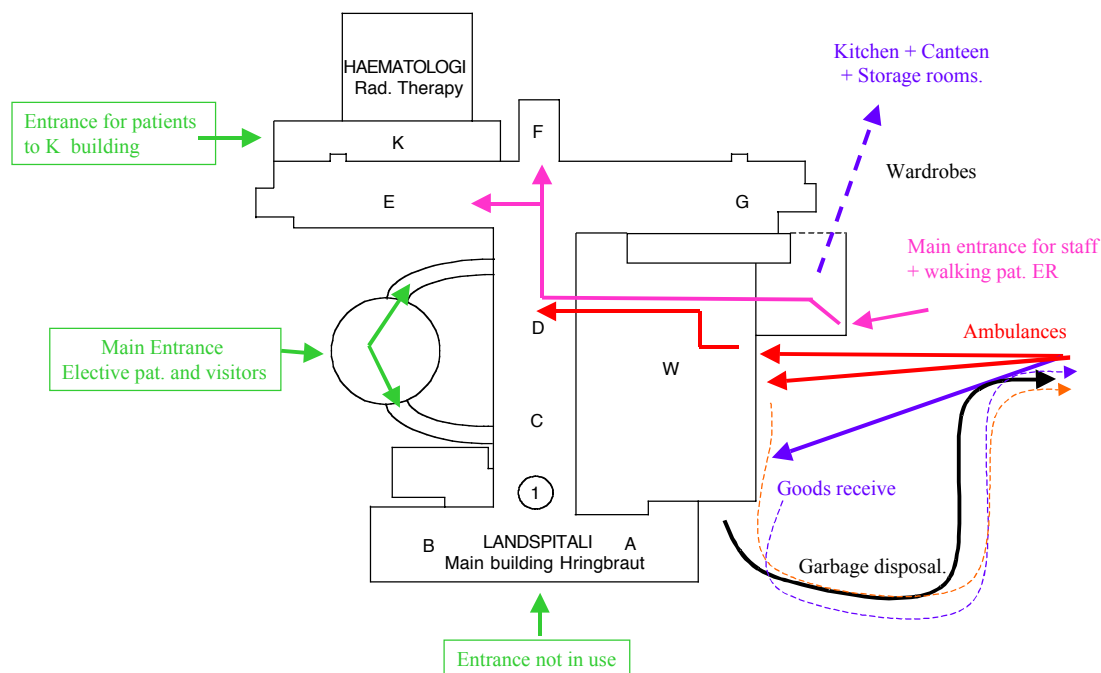

11.2 Future location and logistics

The Gap analysis in the previous chapter showed a present deficit of 8,000 net square meters, distributed over all hospital functions, but mainly in the following areas: somatic wards, laboratory services, university functions, wardrobes and supply functions.

The space gap increases up to approximately 16,000 net square meters in 2020 in more or less the same functions.

Besides the need for more space, both hospital complexes suffers from both external and internal logistical weaknesses, where it is difficult for patients and visitors to find their way, and where staff is using unnecessary amount time for transportation between the functions spread over a large area, with narrow corridors and unlevelled stocks.

To develop a future model for hospital, it will be necessary to look at both possible short-term solutions as well as alternative long-term solutions, which must be mutual coordinated.

The long-term solutions must close the gap, focus on functionality and efficiency and will require different level of investments. The short-term solution will depend on the long-term solution. This means that it is important to decide already at this point on the ambition level for the future in order to make the right decisions for the short-term.

There are in principle three models for the long-term solutions:

- A: the existing buildings Fossvogur and Hringbraut are used to a maximum level
- B: focusing on one location for all the somatic hospital services, Fossvogur or Hringbraut
- C: based on a new built hospital, for instance in Vífilstadir.

In the following chapters a short-term solution is described as well as five alternative long-term solutions.

12 Suggestion for a short-term solution

The short-term solution must take into consideration the present location of functions, possible ways of relocation and which functions it not is wise to relocate on a short-term base.

One of the gaps is the somatic ward, but this problem will to some extent be eliminated when the new children's hospital is finished. Looking at the ward capacity it will almost satisfy the needs. This will in practical terms mean

- 3,000 net m² in Fossvogur for ward
- 6,300 net m² in Hringbraut for ward, including 1800 in the children's hospital

At present the emergency is located at Fossvogur, and in short-term it seems not recommendable to move that function, taken in to consideration the rather poor traffic system for ambulances in Hringbraut. But as soon as a decision has been taken for the long-term solution, the ER must have main priority in consideration of investments in building activities.

Thus the overall basic principles for the short-term solution is:

- Emergency and observation beds stays in Fossvogur together with
 - Medical specialties decided by the management to be in Fossvogur: pulmonology, infectious medicine and neurology
 - Surgical specialties most important to emergency: general surgery, vascular surgery, hot orthopedics and neurosurgery
 - 155 beds in Fossvogur and 3000 m²
- Other specialties in Hringbraut: pediatrics, gynecology/obstetrics, gen. internal medicine, oncology, hematology, urology, plastic surgery, ophthalmology, cold orthopedics, ENT, thoracic surgery, geriatrics (323 beds). These wards are located in building 1, 2 and the new children's hospital
 - The children's hospital is in fact too large for only pediatric services based on the calculated space need. It should be considered to establish other functions in this house, for instance maternity beds and some university functions (an auditorium is already planned). This could give room for e.g. urology and plastic surgery in building 2.
- The related functions (day and outpatient care, offices, patient- and staff service) are suggested to follow the distributions of specialties, in rough terms 30 % in Fossvogur and 70 % in Hringbraut.
- Operation theatres, recovery and intensive care is in the short-term unchanged, and development of these functions are dependent on long-term solutions

- All psychiatry is established in Hringbraut, and located in building 3 (present psychiatry building). If all the psychiatry functions can have this building alone, there will be room enough in building 3.
- The laboratories are spread around in different locations and smaller buildings with little possibility for synergy and efficient operations. It could be considered to build one new building for all laboratories and at the same time improve efficiency. This new building can be located in Fossvogur or elsewhere. The laboratories is however not the first priority for new building activities.
- It is suggested to outsource the pharmaceutical services
- Archives for medical records and x-ray pictures will in the short term remain unchanged.
- University functions should be located where possible
- With respect to service functions we suggest
 - Central administration and technical administration located as today
 - One kitchen in Hringbraut, canteens in both houses.
 - One storage only, if this service cannot be outsourced
 - One sterilization unit only
 - Transportation, cleaning and area for reception of goods/waste in both houses

This gives an overall balance of space in Fossvogur (F) and Hringbraut (H) as follows:

	F Net m2	H Net m2	Total
Present space	15.690	29.700	45.390
Realized space	15.690	29.700	45.390
2001 Need	-		53.410
Unrealized gap			8.020 ***

*** How and where to close the Gap in ER, OR, ICU, X-ray etc. is dependent on the chosen long-term solution.

Based on these assumptions the unrealized gap is still approx. 8,000 net square meters in the short-term, and closing the gap with new buildings cannot start before a decision on the long-term solution has been taken.

13 Suggestions for alternative long-term solutions

13.1 Alternative A1. Further development of the short-term solution

This solution means a further development of the short-term solution described in chapter 12, where you change as little as possible but closes most of the space gap with new buildings.

This alternative is based on the following main principles:

- The distribution of specialties between Fossvogur and Hringbraut remains unchanged from the short-term solution
- Emergency remains at Fossvogur in a new building together with operational theatres, recovery, intensive care and X-ray
- A new building for laboratories is also built

The area balance in this alternative is shown the table below together with alternative A2.

In this case approx. 12,600 net square meters (approx. 25,000 gross square meters) must be new built in Fossvogur. In the new buildings emergency and most important related functions like operational theatres, recovery, intensive care, and x-ray is suggested to be located as well as a new building for laboratories. At the same time approx. 5,200 net squaremeters has to be built in Hringbraut order to meet the requirements for the future. And there is still 3,000 unrealized net squaremeters.

13.2 Alternative A2. More beds in Fossvogur

This solution is based on the same as A1, but with some new-build wards in Fossvogur, which means that more specialties can be gathered here together with the new emergency, OR etc.

This alternative is based on the following main principles:

- Cold orthopedics, thoracic surgery, cardiology, general internal medicine (excl. dermatology) and geriatrics are moved to Fossvogur (all in all 296 beds in F). The rest stays in Hringbraut (all in all 198 in H)
- The majority of day care and outpatient care stays in Hringbraut
- Emergency remains at Fossvogur in a new building together with operational theatres, recovery, intensive care and X-ray
- A new building for laboratories is also built

In this case approx. 3,300 net square meters has to be built for the new wards besides new ER, OR, recovery, ICU, x-ray and lab functions in Fossvogur. In total 13,000 net square meters in Fossvogur. However, in this case we do not have to build any new buildings in Hringbraut. There is though still 2,800 unrealized net squaremeters in the hospital.

The area balance with alternative A1 and A2 is shown the table below:

A1: Development of short-term**A2: More beds in F (60%)**

	F Net m2	H Net m2	Total	F Net m2	H Net m2	Total
Present space	15,690	29,700	45,390	15,690	29,700	45,390
New buildings	3,700 (ER/OR etc.) 3,700 (Lab)	5,200 (various)	12,600	6,000 (ER/OR etc.) 3,300 (wards) 3,700 (Lab)	-	13,000
Realized space	23,090	34,900	57,990	28,690	29,700	58,390
2001 Need			61,220			61,220
Unrealized gap			3,230			2,830

13.3 Alternative B1 and B2. One somatic hospital

These alternatives are based on a further development with focus on one of the two present locations, either Fossvogur or Hringbraut, as the future somatic hospital. We look at both possibilities.

13.3.1 B1. Fossvogur as the somatic hospital

This alternative is based on the following suggestions:

- All somatic specialties are gathered at Fossvogur together with emergency and relevant clinical functions
- Psychiatry is located at Hringbraut
- Service and university functions are mainly located in Hringbraut
- Free space at Hringbraut can be used for other psychiatric functions, rehabilitation and long term functions etc. moved in from other Landspítali locations

In this case where Fossvogur is used as the somatic hospital about 27,000 net square meters (approx. 52,000 gross square meters) must be new built here.

At the same time there will be approx. 11,000 net square meters free for other purposes in Hringbraut.

In order to obtain a better logistic in the hospital we suggest that the ground floors in the A, B, C, E and F wings will be used for day care and outpatient care. The ground floor in a new G wing is used for emergency. In the following illustration one idea for a more coherent hospital is shown:

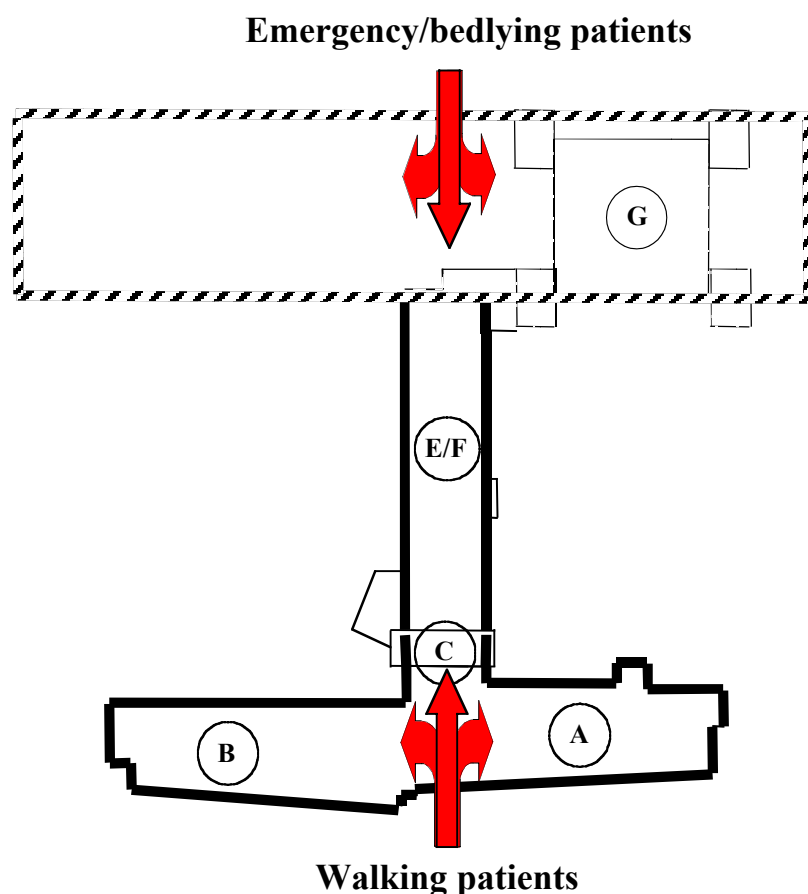

13.3.2 B2. Hringbraut as the somatic hospital

This alternative is based on the following suggestions:

- All somatic specialties are gathered at Hringbraut together with emergency and relevant clinical functions
- Psychiatry could also be located at Hringbraut as today, but in this alternative psychiatry is located at Fossvogur
- Service and university functions are mainly located in Fossvogur

- Free space at Fossvogur can be used for other psychiatric functions, rehabilitation and long term functions etc. moved in from other Landspítali locations

In this case where Hringbraut is used as the somatic hospital about 18,000 net square meters (approx. 35,000 gross square meters) must be new built, and about 2,000 net square meters will be free for other purposes in Fossvogur.

It will, however, be necessary to eliminate a number of older, smaller buildings, like the buildings 6, 7, 10,11 and 14 (perhaps also building 16) as well as some of the add-ons to the main building. We suggest that the W-wing, the X-ray annex and the entrance be removed in order to obtain vacant space for new buildings and a well-connected building complex with a good traffic system.

This means that approx. 2,500 net m² has to be eliminated. All the space in these buildings that have been demolished must be rebuilt somewhere else in order to close the gap. If the acute psychiatry remains in Hringbraut it will also be necessary to replace those square meters, approx. 3,700 net m². This means in practical terms that approx. 6,000 net m² more is to be new built in the Hringbraut solution.

As in the B1 alternative a better logistic can be obtained in Hringbraut by using the ground floors for day care, outpatient care and emergency. In the following illustration one idea for a more coherent hospital is shown:

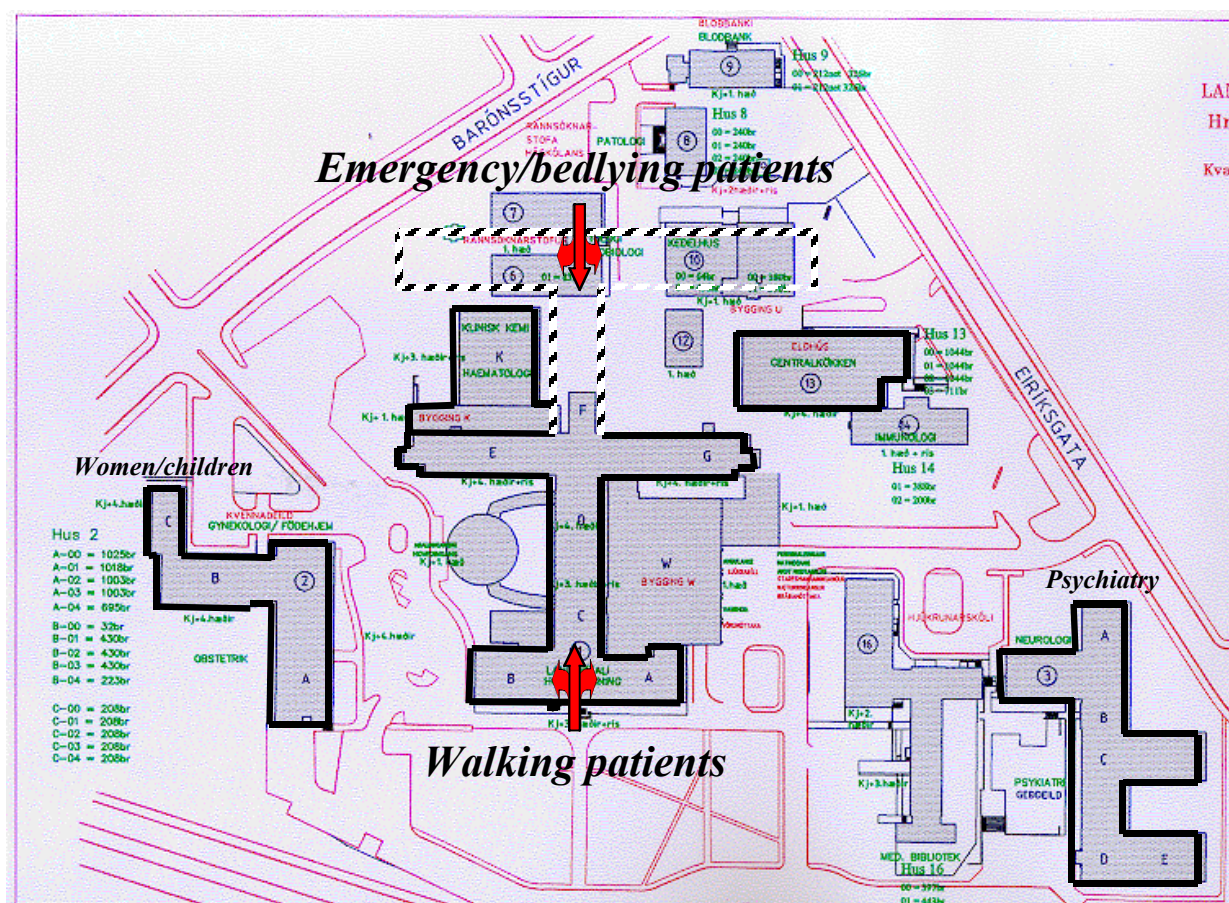

Only the buildings marked up with black remains.

A total area balance for alternative B1 and B2 is shown in the following table.

B1: Somatic hospital in F

B2: Somatic hospital in H

	F Net m2	H Net m2	Total	F Net m2	H Net m2	Total
Present space	15,690	29,700	45,390	15,690	29,700	45,390
New buildings	23,500 (Various) 3,700 (Lab)	-	23,500	3,700 (Lab)	14,000 (various) + 6,000 (replace eliminated . buildings & psych)	20,000
Realized space	42,890	18,330	61,220	17,520	43,700	61,220
2001 Need			61,220			61,220
Unrealized gap			0			0
Free space	-	11,370	11,370	1,870	-	1,870

13.4 Alternative C. New hospital

In case of a new hospital built at for example Vífilsstadir all 61,000 net square meters have to be new built and all of Hringbraut and Fossvogur will be free for other purposes. In this case all present space in Fossvogur and Hringbraut will be available for other purposes.

13.5 Summarizing

Looking at the different long-term alternatives described here, the A alternatives requires the lowest investments, but the somatic hospital functions will also in the long-term be divided into two locations.

If you compare the two A alternatives the investments cost are probably of the same size, but the A2 alternative include only new buildings in Fossvogur where there is a lot of free land, compared to the A1 alternative where you also have to build in Hringbraut.

Looking at the two “one somatic hospital” solutions in alternative B, the Fossvogur solution may at first require the highest investments in terms of new squaremeters, because most of the building capacity today is at Hringbraut. But if the Hringbraut alternative is chosen one must consider rebuilding a number of square meters in order to obtain a well functioning, coherent solution.

So all in all, the alternatives B1 and B2 will more or less require an equal sum of investments. B1 provides more free space and gives fewer disturbances in the everyday work until the new buildings can be taken into use.

The new hospital solution (alternative C) has obvious advantages, but it is at the same time the most cost demanding solution.